



US006879709B2

(12) **United States Patent**
Tian et al.

(10) **Patent No.:** **US 6,879,709 B2**
(45) **Date of Patent:** **Apr. 12, 2005**

(54) **SYSTEM AND METHOD FOR
AUTOMATICALLY DETECTING NEUTRAL
EXPRESSIONLESS FACES IN DIGITAL
IMAGES**

5,410,609 A	*	4/1995	Kado et al.	382/118
6,009,210 A	*	12/1999	Kang	382/276
6,400,835 B1	*	6/2002	Lemelson et al.	382/118
6,556,196 B1	*	4/2003	Blanz et al.	345/419
6,807,290 B1	*	10/2004	Liu et al.	382/118

(75) Inventors: **Ying-Li Tian**, Mount Kisco, NY (US);
Rudolf M. Bolle, Bedford Hills, NY (US)

OTHER PUBLICATIONS

(73) Assignee: **International Business Machines Corporation**, Armonk, NY (US)

Computer Recognition of Human Faces by Takeo Kanade, pp. 47–63.

(*) Notice: Subject to any disclaimer, the term of this patent is extended or adjusted under 35 U.S.C. 154(b) by 638 days.

Manual for the Facial Action Coding System by Paul Ekman, Ph.D. and Wallace V. Friesen, Ph.D., (Paul Ekman, 1978) pp. 1–6.

(Continued)

(21) Appl. No.: **10/051,595**

(22) Filed: **Jan. 17, 2002**

(65) **Prior Publication Data**

US 2003/0133599 A1 Jul. 17, 2003

Primary Examiner—Bhavesh M. Mehta

Assistant Examiner—Sheela Chawan

(74) *Attorney, Agent, or Firm*—Louis J Percello

(51) **Int. Cl.**⁷ **G06K 9/00**

(57) **ABSTRACT**

(52) **U.S. Cl.** **382/118**; 382/170; 382/173;
382/190; 382/199; 340/5.83

A system and method for automatic detecting neutral expressionless faces in digital images and video is described. First a face detector is used to detect the pose and position of a face and find the facial components. Second, the detected face is normalized to a standard size face. Then a set of geometrical facial features and three histograms in zones of mouth are extracted. Finally, by feeding these features to a classifier, the system detects if there is the neutral expressionless face or not.

(58) **Field of Search** 352/103, 107,
352/100, 115, 117, 118, 168, 170, 173,
181, 190, 199, 209, 254, 276, 165; 356/71;
340/5.82, 5.83

(56) **References Cited**

U.S. PATENT DOCUMENTS

5,164,992 A * 11/1992 Turk et al. 382/118

38 Claims, 18 Drawing Sheets

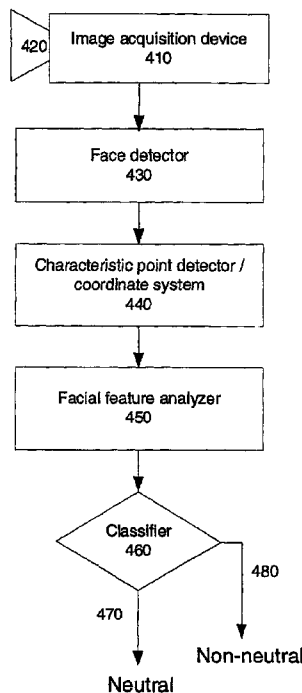

OTHER PUBLICATIONS

Recognizing Human Facial Expressions from Long Image Sequences Using Optical Flow by Yaser Yacoob and Larry S. Davis, IEEE Transactions on Pattern Analysis and Machine Intelligence, vol. 18, No. 6, Jun. 1996, pp. 636–642.

Classifying Facial Actions by Gianluca Donato, Stewart Bartlett, Joseph C. Hager, Paul Ekman and Terrence J. Sejnowski, IEEE Transactions on Pattern Analysis and Machine Intelligence, vol. 21, No. 10, Oct. 1999, pp. 974–989.

Recognizing action Units for Facial Expression Analysis by Ying–li Tian, Member, IEEE, Takeo Kanade, Fellow, IEEE and Jeffrey F. Cohn, Member, IEEE, IEEE Transactions on Pattern Analysis and Machine Intelligence, vol. 23, No. 2, Feb. 2001, pp. 97–115.

Computer Vision by Dana H. Ballard and Christopher M. Brown, pp. 68–70, pp. 75–80.

Human Face Detection in Visual Scenes by Henry A. Rowley, Shumeet Baluja and Takeo Kanade, Nov. 1995, pp. 1–24.

Recognizing Faces Showing Expressions by Yaser Yacoob Heung–Man Lam and Larry S. Davis (To appear in International Workshop on Automatic Face–and Gesture–Recognition).

Learning Human Face Detection in Cluttered Scenes by Kah–Kay Sung and Tomaso Poggio (to appear in proco. 6th Intl. Conf. CAIP' 95, Prague, Czech Republic, pp. 1–8).

Color Indexing (Using Color As A Reference Index) by Michael J. Swain, Dana H. Ballard, International Journal of Computer Vision, 7:1, 11–32 (1991), 1991 Kluwer Academic Publishers, Manufactured in The Netherlands.

Proceedings of the Fourth International Joint Conference on Pattern Recognition by Motoi Suwa, Noboru Sugie and Keisuke Fujimura, Nov. 7–10, 1973, Kyoto, Japan, Sponsored by the International Association for Pattern Recognition (IAPR): an Affiliate Member of IFIP, pp. 408–411.

* cited by examiner

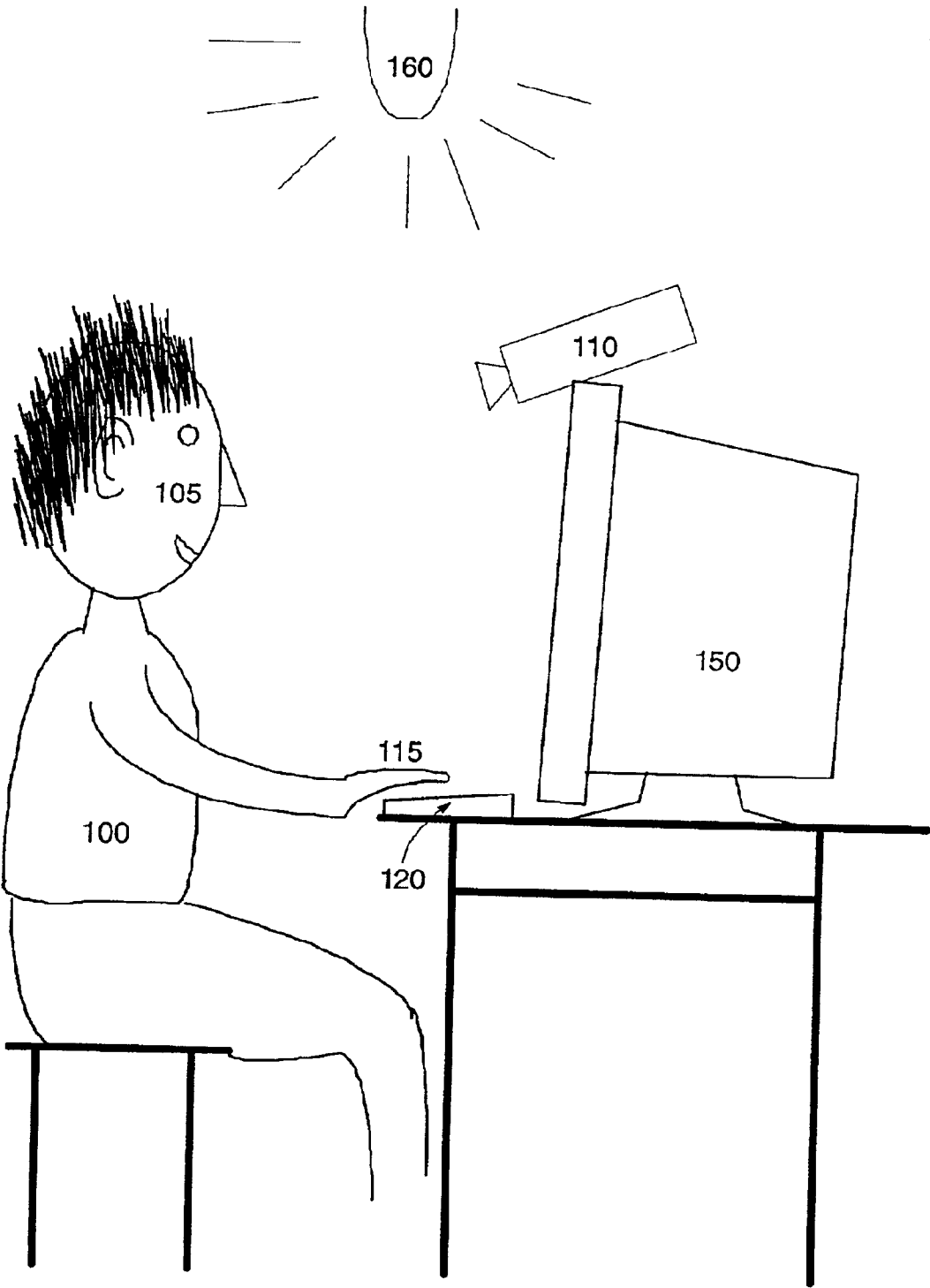

Figure 1

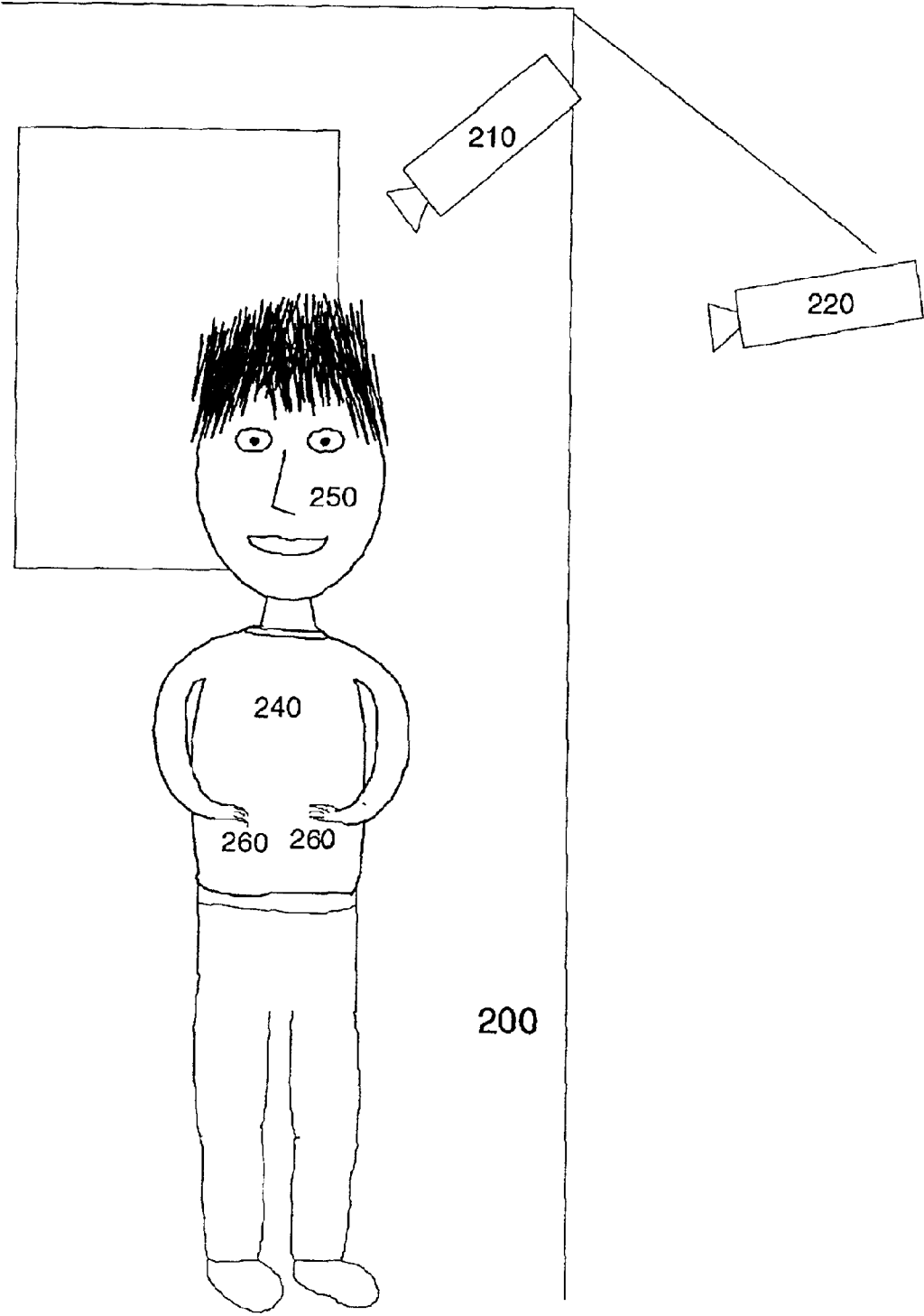
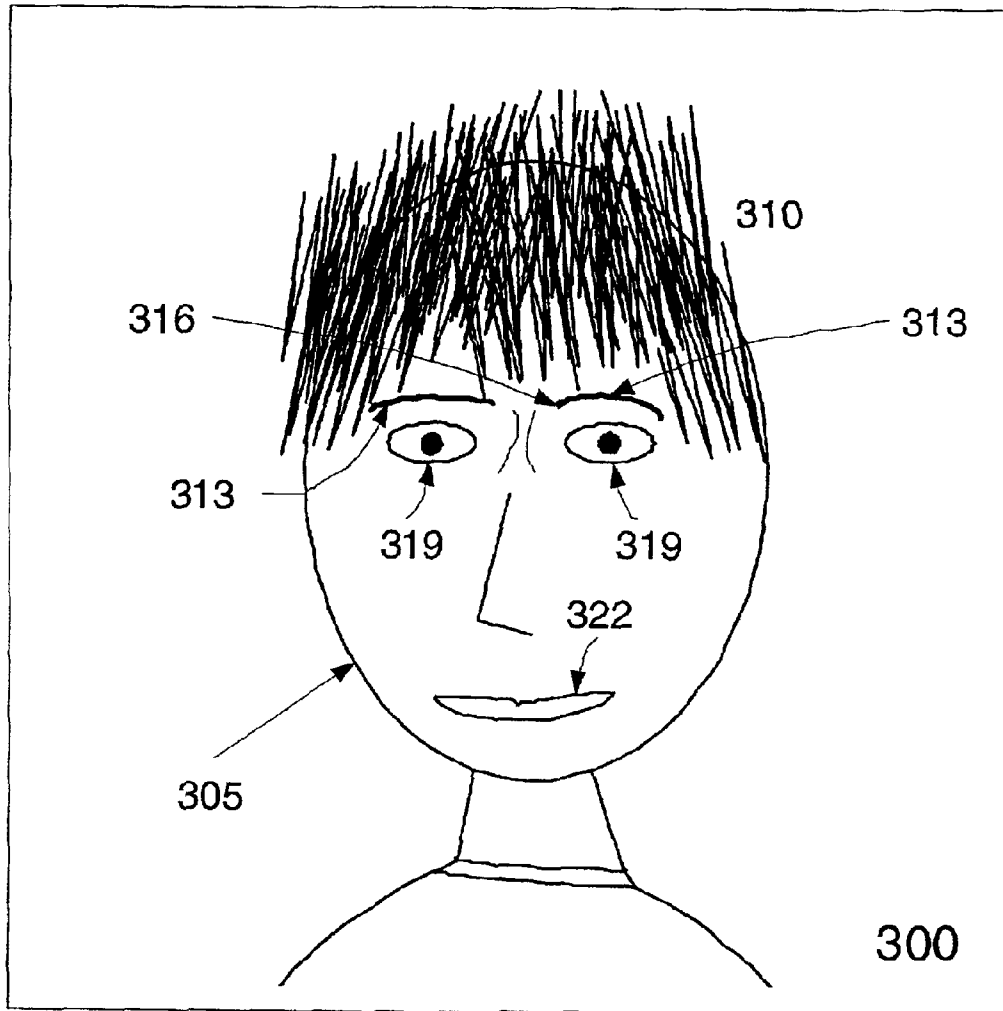

Figure 2



Neutral expression

No expression

PRIOR ART

Figure 3A

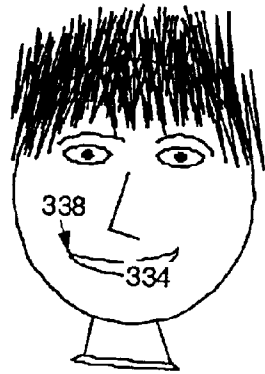

Happy, 330

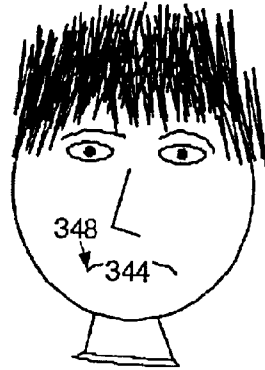

Sad, 340

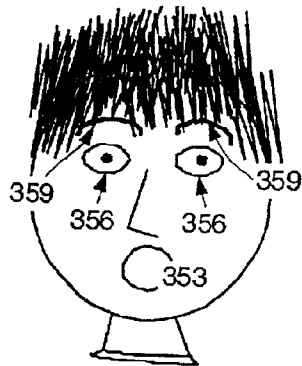

Surprise, 350

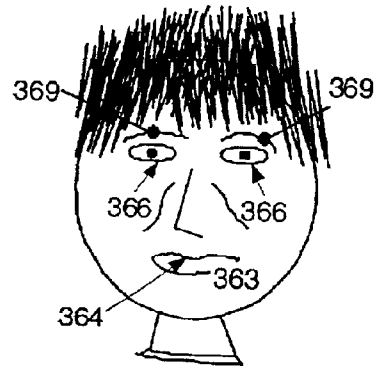

Disgust, 360

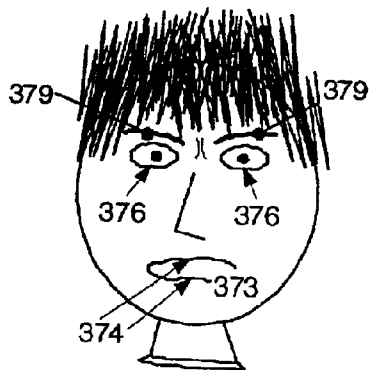

Fear, 370

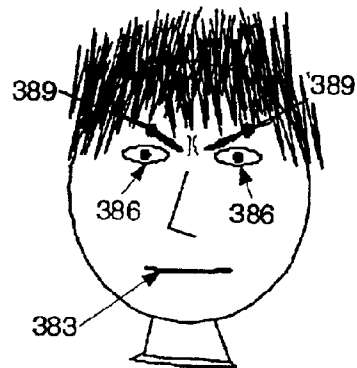

Anger, 380

PRIOR ART

Figure 3B

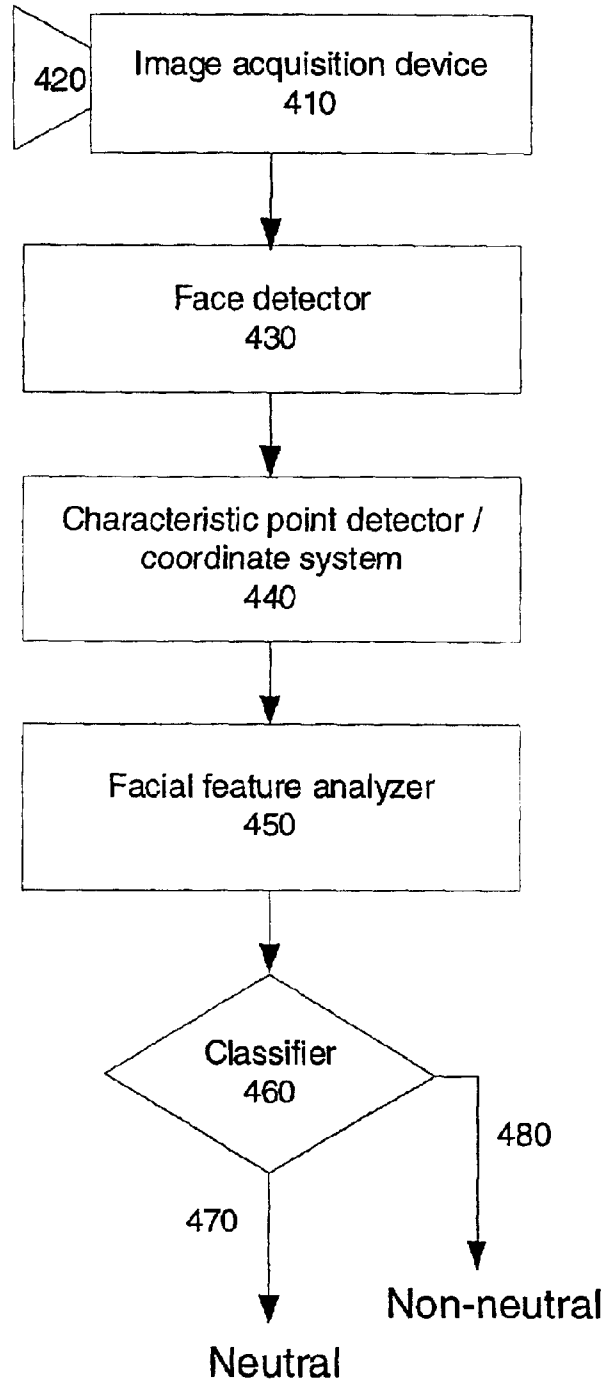

Figure 4

PRIOR ART

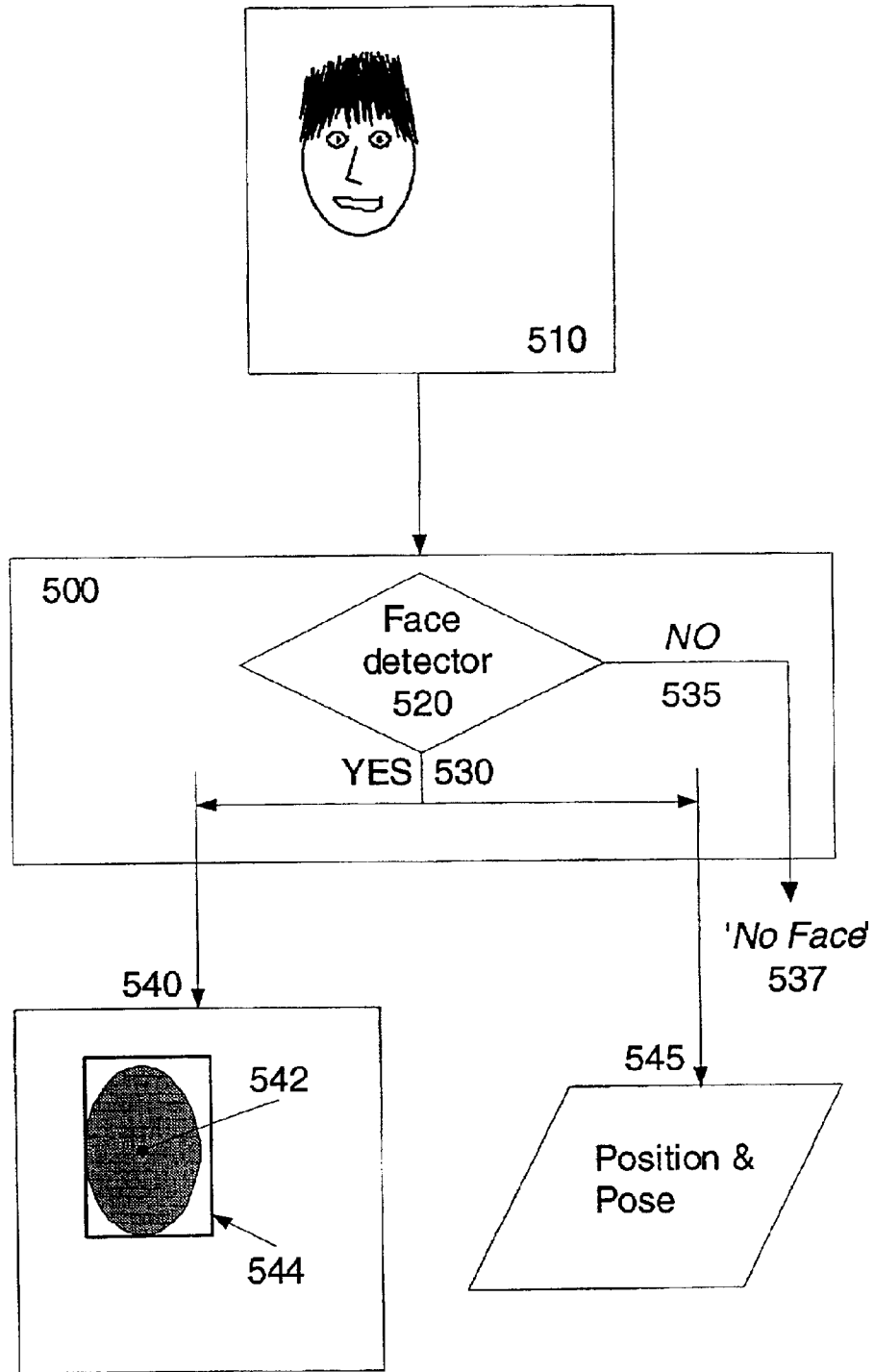

Figure 5A

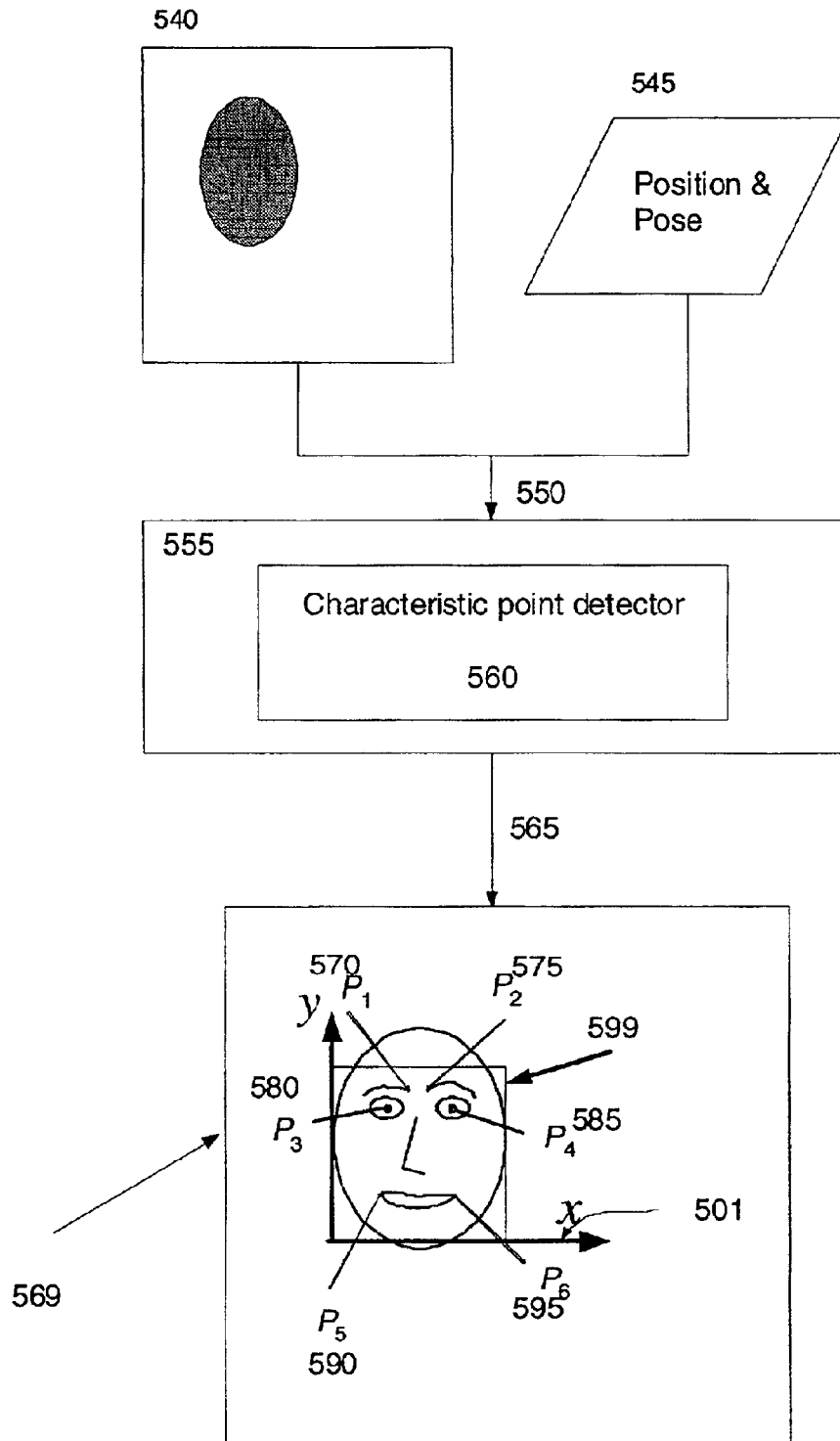

Figure 5B

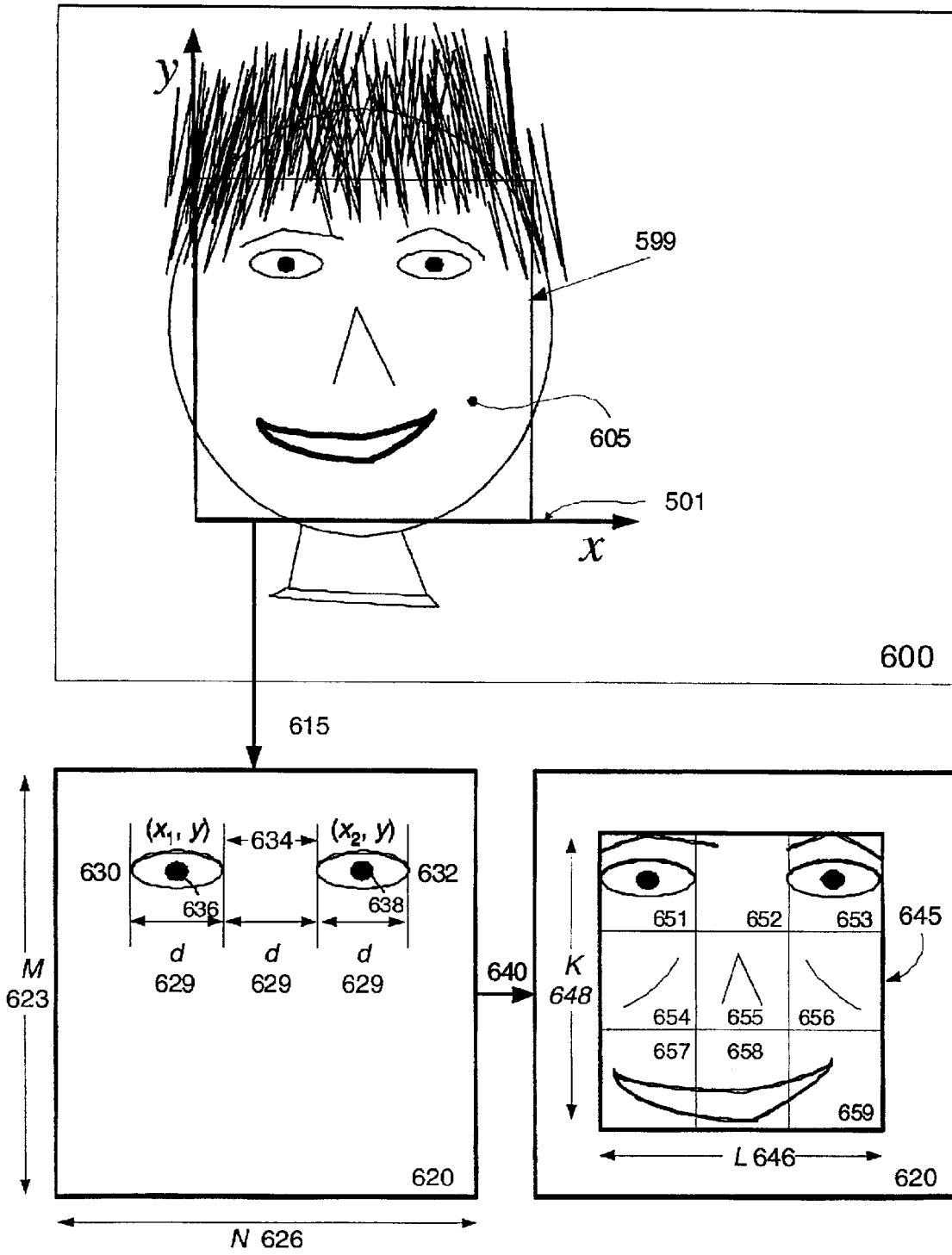

Figure 6

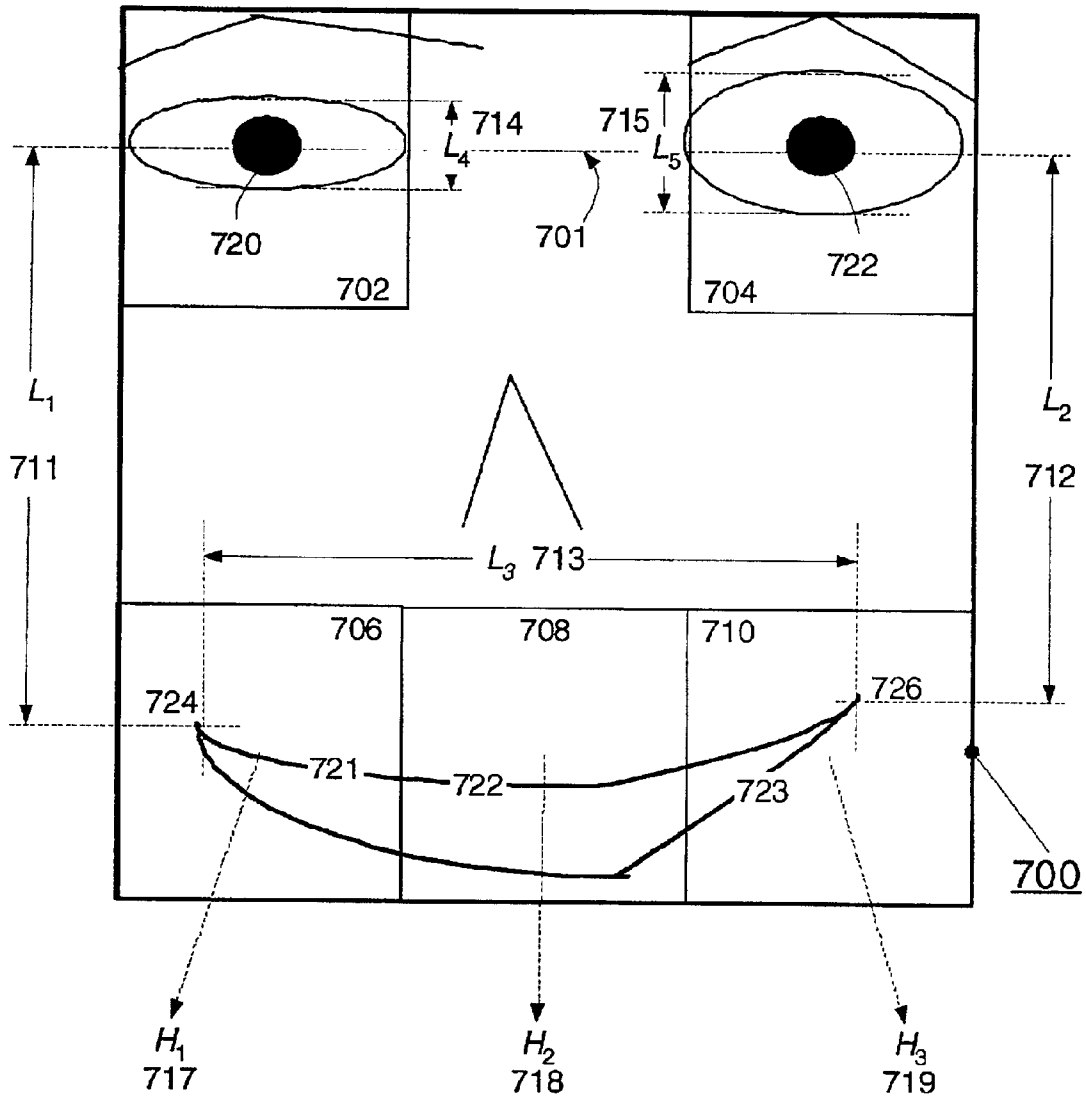

Figure 7A

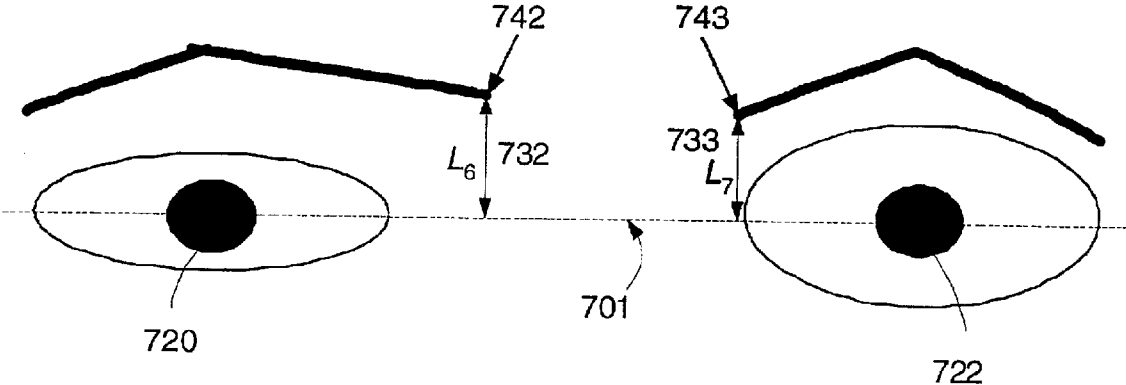

Figure 7B

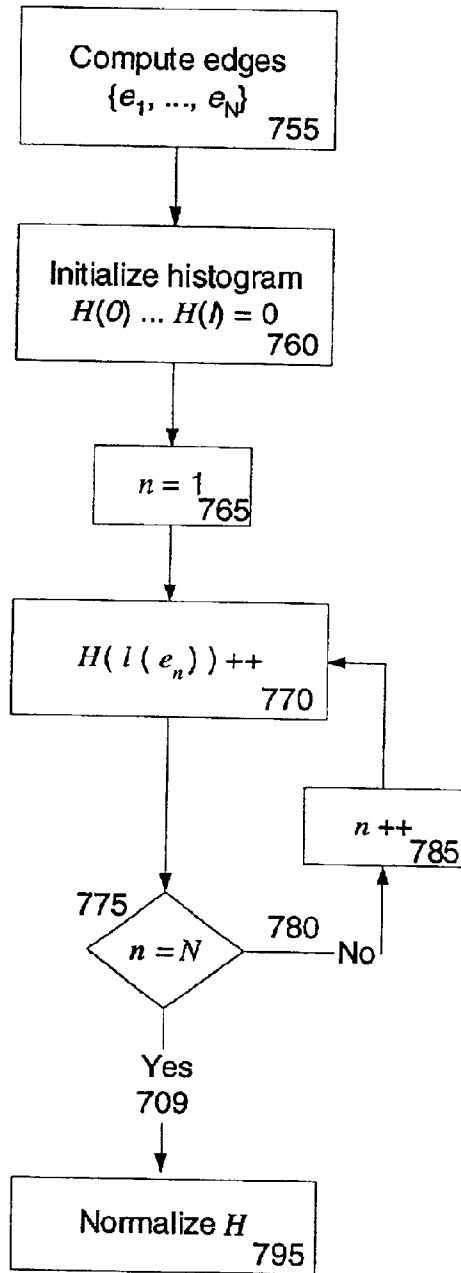
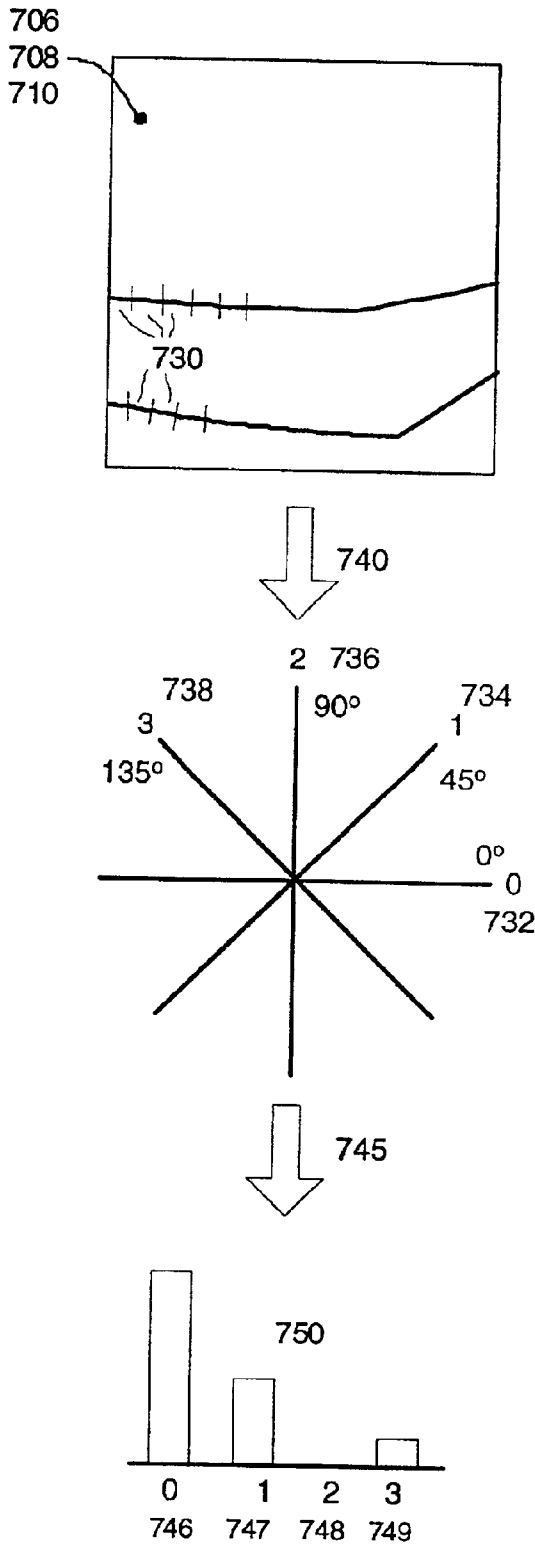

Figure 7C

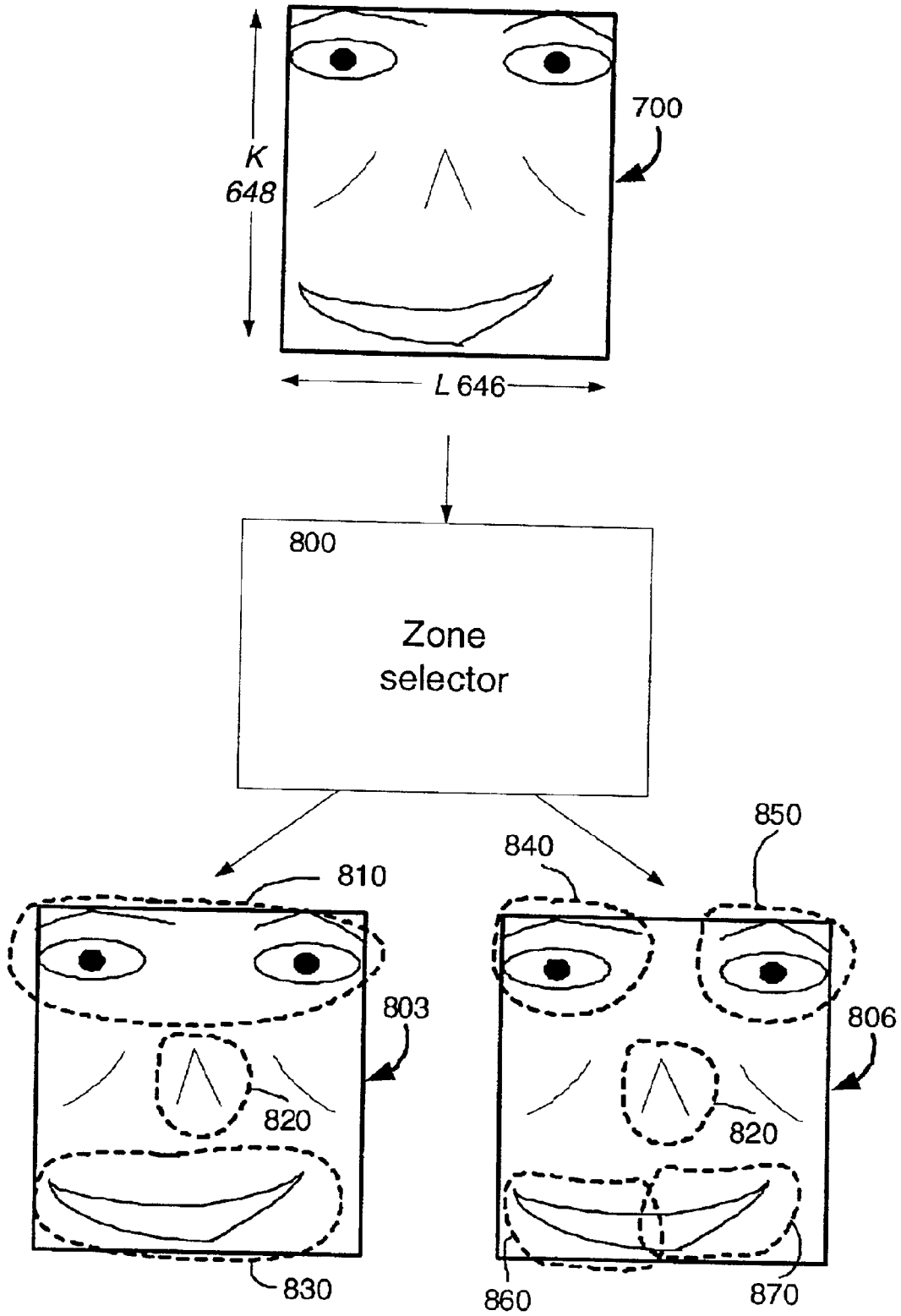

Figure 8

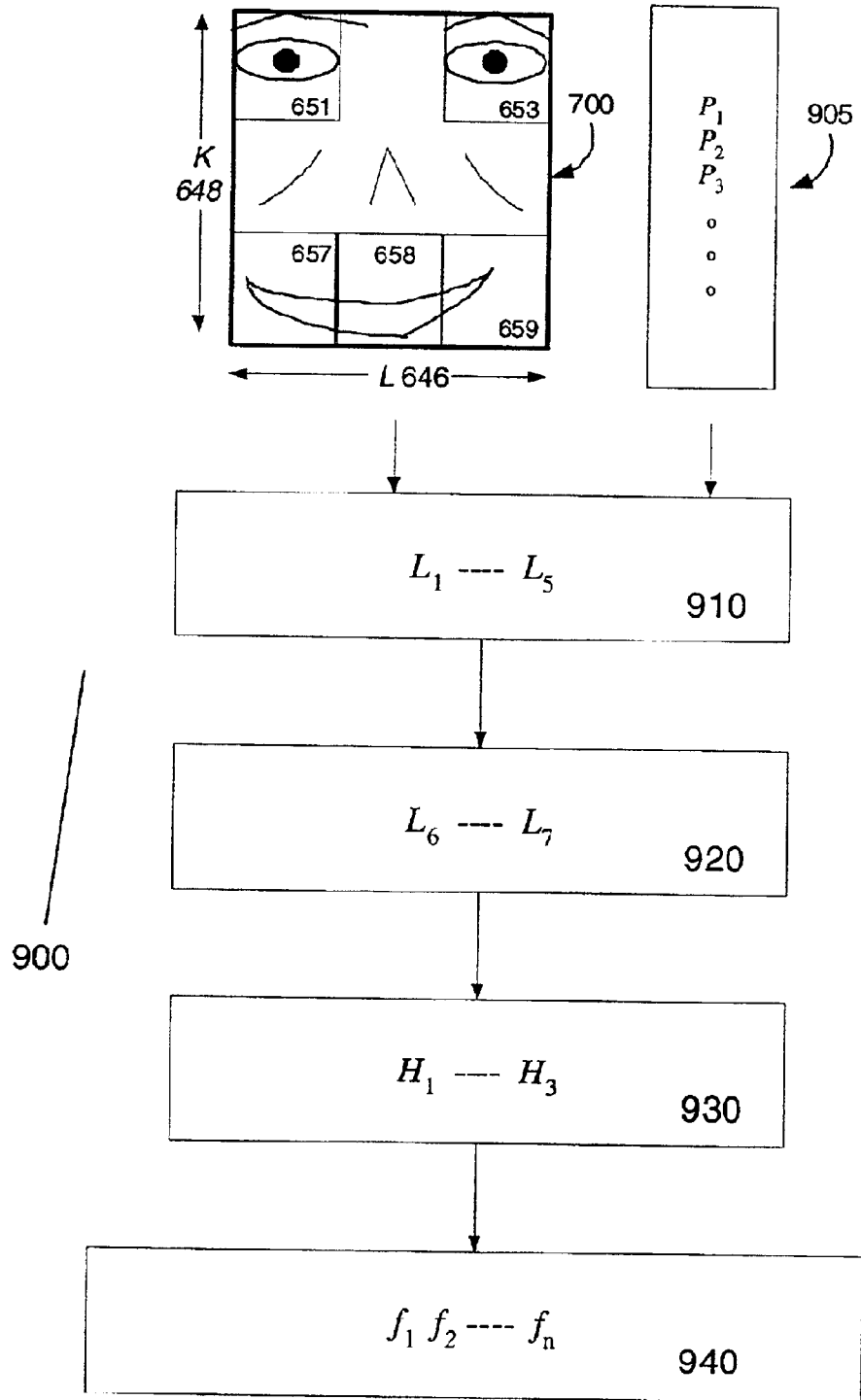

Figure 9

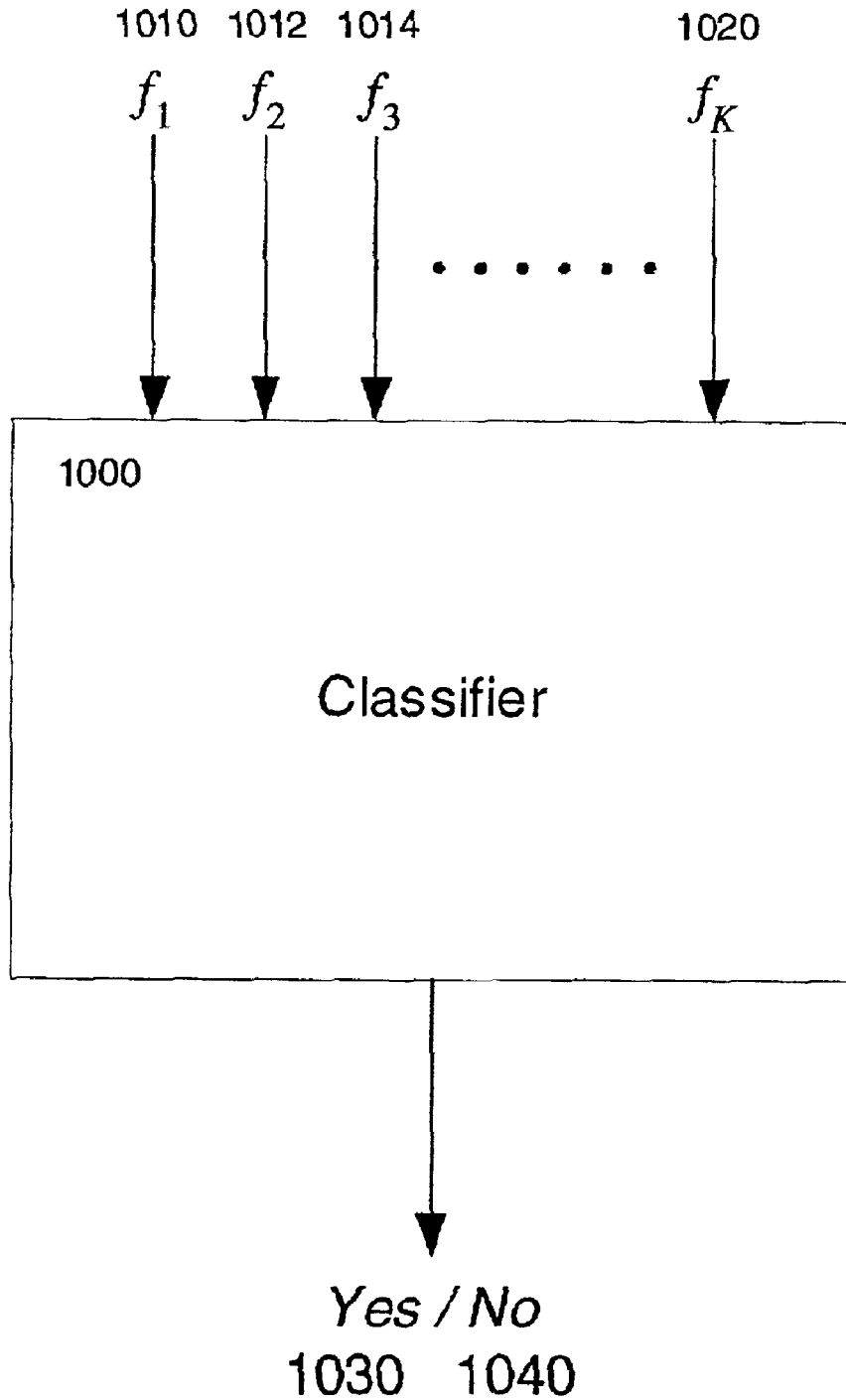

Figure 10

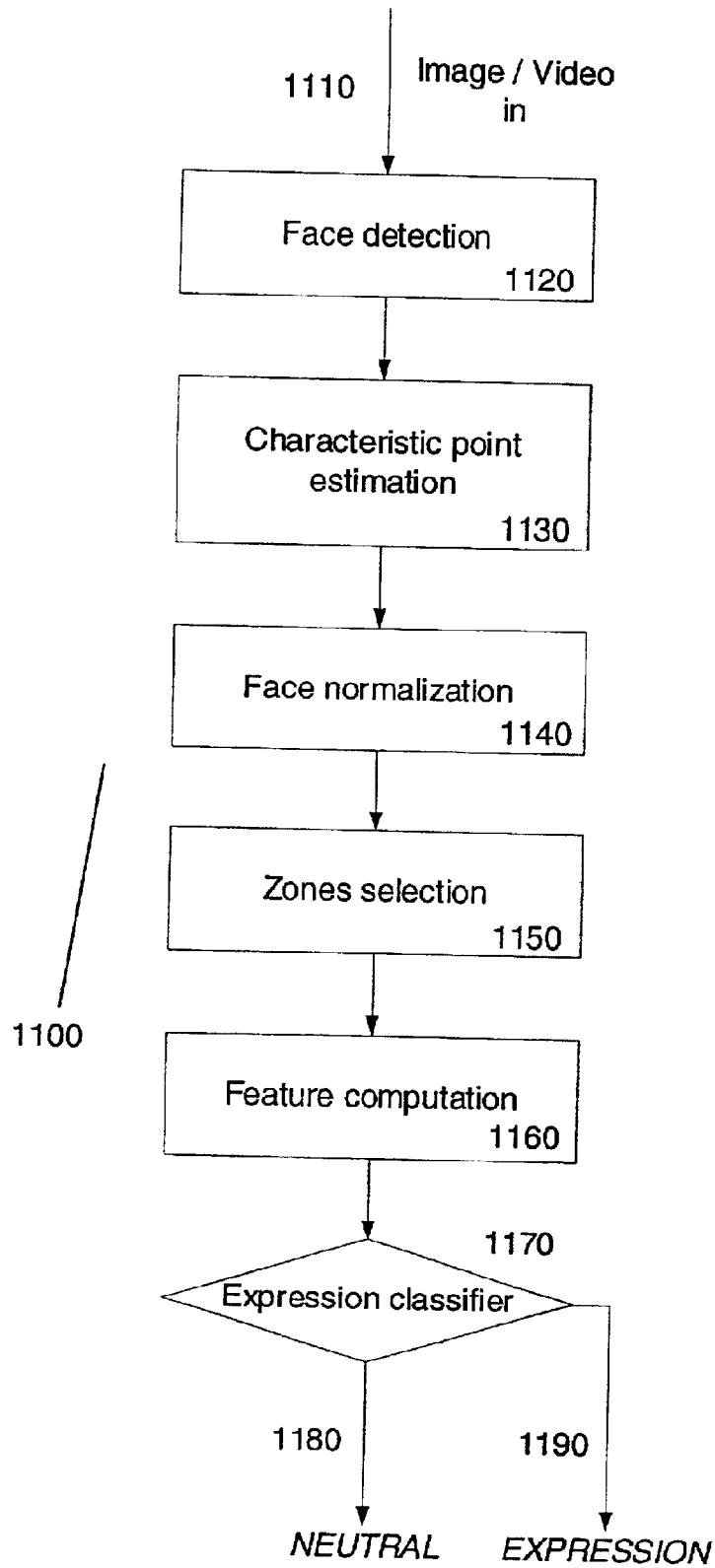

Figure 11

TRAINING PHASE 1200

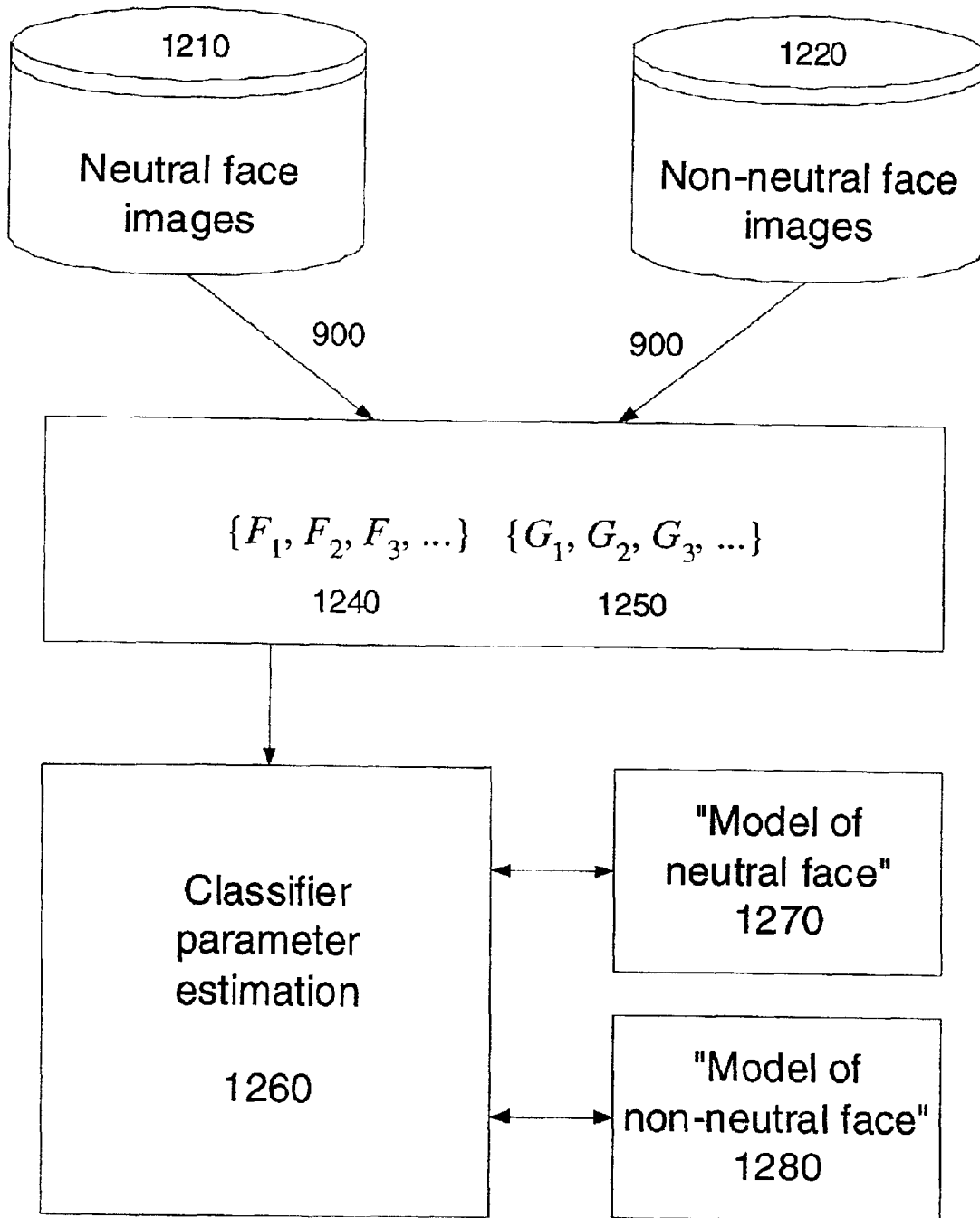

Figure 12

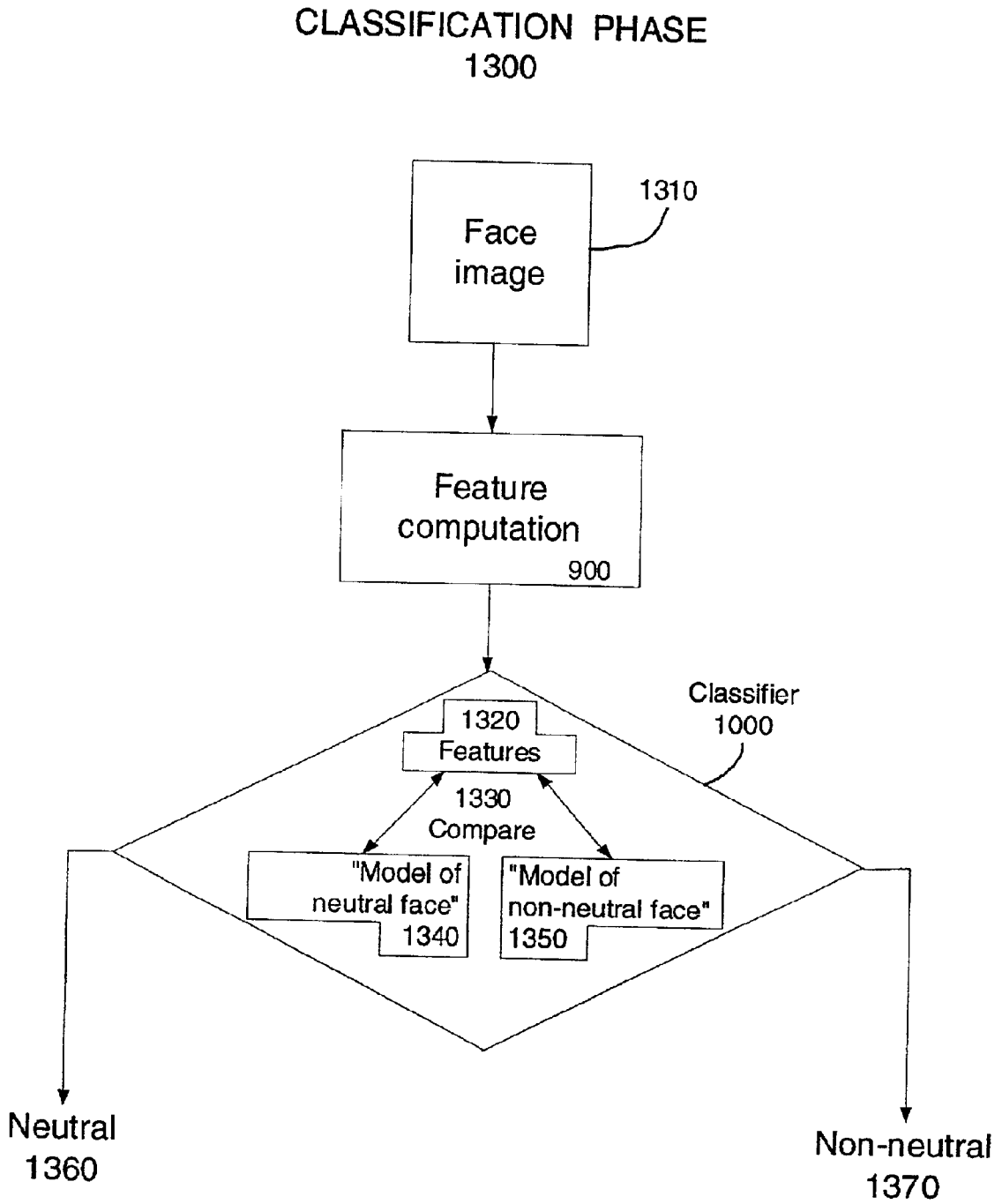

Figure 13

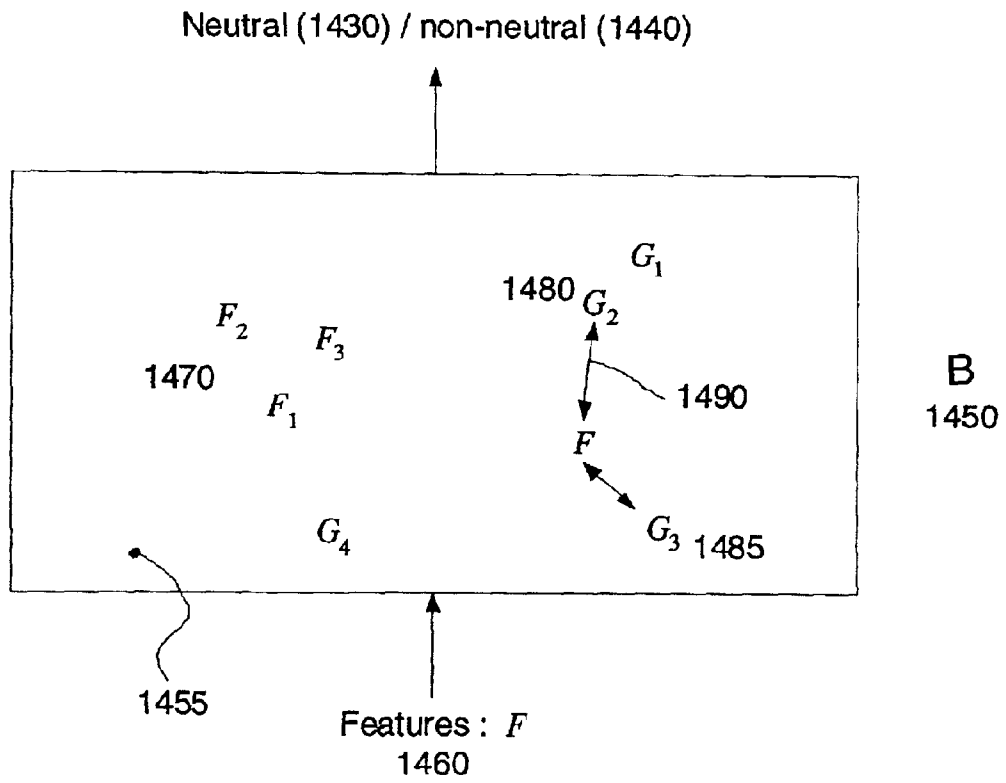
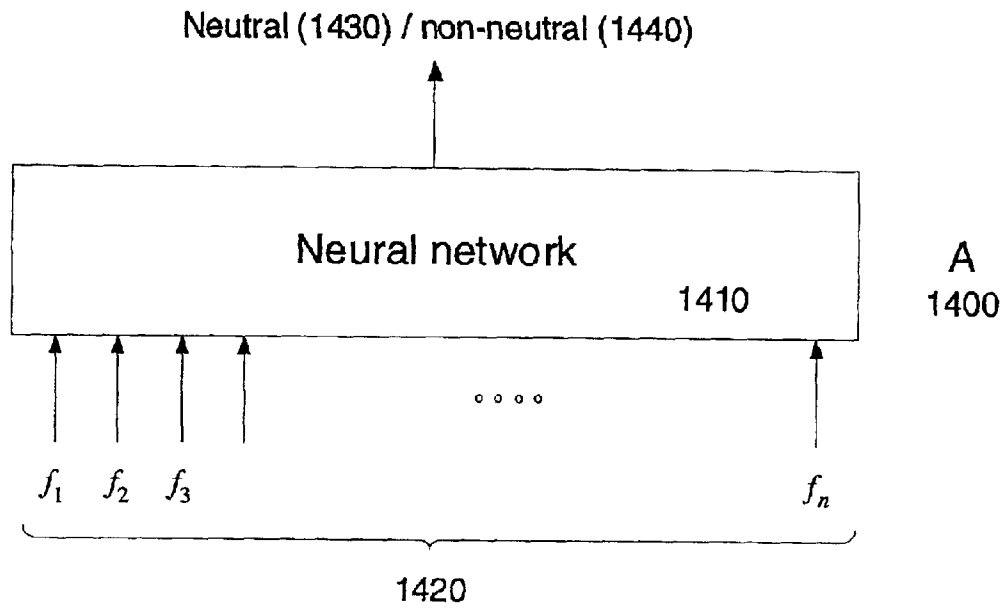

Figure 14

SYSTEM AND METHOD FOR AUTOMATICALLY DETECTING NEUTRAL EXPRESSIONLESS FACES IN DIGITAL IMAGES

FIELD OF THE INVENTION

This invention relates to the field of processing and interpreting of digital images and video that contain human faces. More specifically, this invention relates to the detection, recognition and facial expression classification of the appearances of human faces in digital images and video.

BACKGROUND OF THE INVENTION

A neutral expressionless face is a relaxed face without contraction of facial muscles and without facial movements. It is the state of people's face most of the time. The appearance of a neutral face is needed for all existing automated facial expression analysis systems. That is, to classify a facial expression, a generic automated neutral expressionless face appearance is needed and provided by a human operator. Face expression classification then, in general, has three stages: (i) face detection and normalization; (ii) facial feature extraction and representation; and (iii) comparison of the feature representation to a feature representation of the hand-annotated neutral face appearance. In addition, compared to enrolling a face with dramatic expressions in a face based person authentication system, the performance of such face based authentication systems can be much improved by enrolling and authenticating neutral faces.

Face detection and normalization are often used techniques in the general area of image and video processing. Face detection is the first step of many face recognition systems. Face detection is also the first step in facial expression analysis for (say) human-computer interaction. A face detection system finds positions and scales of the faces in images and videos. A robust face detector flexibly and reliably detects the face in the image or video, regardless of lighting conditions, background clutter in the image, multiple faces in the image, as well as variations in face position, scale, pose and expression.

The accurate detection of human faces in arbitrary scenes is the most important process involved. The face component template, skin color, contour, eigenfaces (U.S. Pat. No. 5,164,992 to Turk and Pentland), and other features can be used for face detection. Many face detectors have been developed in past 20 years. Some example algorithms for locating faces in images can be found in (Sung and Poggio) and (Rowley, Baluja, and Kanade).

Kah-Kay Sung and T. Poggio. Learning human face detection in cluttered scenes. In *Computer Analysis of Images and Patterns*, pages 432–439, 1995. (Sung and Poggio)

Henry A. Rowley, Shumeet Baluja, and T. Kanade. Human face detection in visual scenes. *Technical Report CMU-CS-95-158*, School of Computer Science, CMU, Pittsburgh, Pa., July 1995. (Rowley, Baluja, and Kanade)

These references are incorporated by reference in its entirety.

Oftentimes, face normalization is a necessary preprocessing step for face recognition and facial expression analysis. Generally, the face appearance images encompass a great deal of variance in position, scale, lighting because of body and/or head motion, and lighting changes because of envi-

ronment changes. Thus, it is necessary to compensate or normalize a face for position, pose, scale, and illumination so that the variance due to the above mentioned causes is minimized.

Furthermore, expression and facial detail changes result in changes in the face appearance images and these changes also somehow have to be compensated for.

After the face detection and localization stage there is the face normalization stage. Here the eyes, the nose or the mouth are identified using direct image processing techniques (such as template matching, see below). Assume for now that the line segment between the eyes is known and that the exact location for the nose tip is available. The detection of the location of these feature points (eyes, nose, and mouth) gives an estimate of the pose the face. Once the 2D pose or the 3D position and orientation of the face is known, it is possible to revert the effect of translation and rotation and synthesize a standardized, frontal view of the individual. Furthermore, the position of the feature points allow for a rough segmentation of the contour of the face to discard distracting background information. Once segmented, a color histogram of the face alone can be computed to compensate for lighting changes in the image by transforming the color histogram to some canonical form.

If faces could be exactly detected and located in the scene, the techniques for face authentication, face recognition, or facial expression analysis can be readily applied to these detected face. Face authentication systems verify the identity of particular people in real-time (e.g., in a security monitoring system, location tracking system, etc.), or allow access to some resource to a selected group of enrolled people and deny access to all others (e.g., access to a building, computer, etc.). Multiple images per person are often available for training and real-time identification is, of course, a necessity.

Compared to the problem of face authentication, face recognition/identification is a much more complex problem. Given an image of human face, a face recognition system compares the face appearance to models or representations of faces in a (possibly) large database of identities (e.g., in a police database of mugshots) and reports the identity of the face if a match exists. These systems typically return a list of the most likely matches in the database. Often only one image is available per person. For forensic applications like mugshot searches, it is usually not necessary for face identification to be done in real-time. For background check, for example, on points of entry or exit such as airports, immediate responses are required.

The techniques for face identification can be categorized as either feature-based (geometric) or template-based/appearance-based (photometric), where the latter has proven more successful. Template-based or appearance-based methods use measures of facial similarity based on standard Euclidean error norms (that is, template matching) or subspace-restricted error norms (e.g., weighted eigenspace matching), see U.S. Pat. No. 5,164,992 to Turk and Pentland. The latter technique of "eigenfaces" has in the past decade become the "golden standard" to which other algorithms are often compared.

Facial expressions are one of the most powerful, natural, and immediate means by which human beings communicate their emotions and intentions. The human face expresses emotions faster than people verbalize or even realize their feelings. Many psychologists have been studying human emotions and facial expressions and found that the same expression might have radically different meanings in different cultures. However, it is accepted by 20th century

psychologists that six universal expressions (i.e., happiness, sadness, disgust, anger, surprise, and fear) are not changing too much for different cultures. In addition, Ekman and Friesen have developed a Facial Action Coding System (FACS) to describe facial behavior in term of its constituent muscle actions. The details about FACS can be found in (Ekman & Friesen)

P. Ekman and W. V. Friesen, *Facial Action Coding System: A Technique for the measurement of Facial Movement*. Palo Alto, Calif.: Consulting Psychologists Press, 1978. (Ekman & Friesen)

This reference is incorporated by reference in its entirety.

In the past decade, much progress has been made to build computer systems that understand and use this natural form of human communication for human-computer interaction. Most of the facial expression analysis systems focus only on the six universal expressions. Recently, some researchers have been working on more subtle facial expression movements based on the Facial Action Coding System from Ekman and Friesen. Facial expression analysis systems have applications in retail environments (happy and unhappy customers), human computer interaction (e.g., the computer reacts to the user's frame of mind), lie detection, surveillance and image retrieval.

Facial feature extraction and building a face representation are important aspects of the field of processing of images and video that contain faces. Multiscale filters, that operate at multiple levels of resolution, are used to obtain the pre-attentive features (features such as edges and small regions) of objects. Based on these features, different structural face models have been investigated to locate the face and facial features, such as eyes, nose and mouth. The structural models are used to characterize the geometric pattern of the facial components. These models, which are texture and feature models, are used to verify the face candidate regions detected by simpler image processing operations. Since the eyeballs (or pupils) are the only features that are salient and have strong invariant property, the distance between these is often used to normalize face appearances for recognition purposes. Motivated by this fact, with the face detected and the structural information extracted, a precise eye localization algorithm is applied using contour and region information. Such an algorithm detects, ideally with a sub-pixel precision, the center and the radius of the eyeballs in the face image. The localized eyes now can be used for an accurate normalization of images, which greatly reduces the number of possible scales that need to be used during the face recognition process. The work by Kanade (Kanade) was the first to present an automatic feature extraction method based on ratios of distances and reported a recognition rate of between 45–75% on a database of 20 people.

T. Kanade, "Picture Processing by Computer Complex and Recognition of Human Faces," PhD Thesis, Kyoto University, 1973. (Kanade)

This reference is incorporated by reference in its entirety.

Different facial features have been used for facial image processing systems, for example, face characteristic points, face components, edges, eigenfaces (U.S. Pat. No. 5,164,992 to Turk and Pentland), histograms, and so on.

Face characteristic points are the location of face components. For example, inner corners, of the eyebrows, inner corners of the eyes, outer corner of the eyes, center of nose, lip corners.

Edge detection refers to a class of technologies to identify sharp discontinuities in the intensity profile of images. Edge detectors are operators that compute differences between

pairs of neighboring pixels. High responses to these operators are then identified as edge pixels. Edge maps can be computed in a single scan through the image. Examples of edge detection are the Gradient- and Laplacian-type edge finders and edge templates such as Sobel.

Gradient- and Laplacian-type edge finders and edge templates are described more fully in D. Ballard and C. Brown, *Computer Vision*, Prentice-Hall: N.J., 1982, pages 75–80. (Ballard and Brown a). A histogram is common terminology for a uni-variate (i.e., one-variable) distribution, or, better said, a probability mass distribution. That is, a histogram accumulates the relative frequencies of values of this variable in a one-dimensional array. Several types of histograms can be constructed: categorical, continuous, difference, and comparative. Details of each type of histogram can be found in M. Swain and D. Ballard, "Color indexing," *International Journal of Computer Vision*, Vol. 7, No. 1, pp. 11–32, 1991. This reference is incorporated by reference in its entirety.

To determine a histogram for a set of variables measured on a continuous scale, divide the range (the scale) between the highest and lowest value into several bins of equal size. Then increment by 1 the appropriate bin of the histogram for each quantized value in the set. (Each quantized value is associated with one of the histogram bins.) The number in each bin of this frequency histogram represents the number of quantized values in the original set.

Template matching is a general method for localizing and/or recognizing objects. In template matching, a template image represents the object, which is to be located in a one or more target images. This is achieved by matching the template image to all (or many) of the possible locations it could appear in the target image. A distance function (typically a simple Euclidean distance) is applied to the template and the image portion covered by the template to measure the similarity of the template and the image at a given location. The matching algorithm then picks the location with smallest distance as the location of the template image in the target image.

There are several variations to this basic algorithm. A first one is the use of more sophisticated distance functions. This may be necessary for images, which have different overall brightness than the template image or varying brightness. Another set of variations attempts to reduce the number of possible locations which are actually matched. One such method is to use image pyramids. Another method is to only match every few pixels, and then for promising match locations, attempt to match all the pixels in the neighborhood.

Template matching (often also referred to as correlation or normalized correlation), is described fully in D. Ballard and C. Brown, *Computer Vision*, Prentice-Hall: N.J., 1982, pp. 68–70. (Ballard and Brown b). This reference is incorporated by reference in its entirety.

Classifiers play an important role in the analysis of images and video of human faces. For example, some classifier or several classifiers are used to classify the facial expression based on the extracted face features. To develop a procedure for identifying images or videos as belonging to particular classes or categories (or for any classification or pattern recognition task, for that matter), supervised learning technology can be based on decision trees, on logical rules, or on other mathematical techniques such as linear discriminant methods (including perceptrons, support vector machines, and related variants), nearest neighbor methods, Bayesian inference, neural networks, etc. We generically refer to the output of such supervised learning systems as classifiers.

Most classifiers require a training set consisting of labeled data, that is, representations of previously categorized media

items (i.e., face appearances), to enable a computer to induce patterns that allow it to categorize hitherto unseen media items. Generally, there is also a test set, also consisting of labeled data, that is used to evaluate whatever specific categorization procedure is developed. In academic exercises, the test set is usually disjoint from the training set to compensate for the phenomenon of overfitting. In practice, it may be difficult to get large amounts of labeled data of high quality. If the labeled data set is small, the only way to get any useful results at all may be to use all the available data in both the training set and the test set.

To apply standard approaches to supervised learning, the media segments (face appearances) in both the training set and the test set must be represented in terms of numbers derived from the face appearances, i.e., features. The relationship between features extracted for the purposes of supervised learning and the content of a face image/video has an important impact on the success of the enterprise, so it has to be addressed, but it is not part of supervised learning per se.

From these feature vectors, the computer induces classifiers based on patterns or properties that characterize when a face image/video belongs to a particular category. The term "pattern" is meant to be very general. These patterns or properties may be presented as rules, which may sometimes be easily understood by a human being, or in other, less accessible formats, such as a weight vector and threshold used to partition a vector space with a hyperplane. Exactly what constitutes a pattern or property in a classifier depends on the particular machine learning technology employed. To use a classifier to categorize incoming hitherto unseen media segments, the newly arriving data must not only be put into a format corresponding to the original format of the training data, but it must then undergo a further transformation based on the list of features extracted from the training data in the training phase, so that it finally possesses a representation as a feature vector that permits the presence or absence of the relevant patterns or properties to be determined.

Classifying in an automated fashion whether a face has a neutral expression is an important problem. The ability to detect whether a face image is expressionless has, in general, many applications since it eliminates one complicated degree of freedom, the facial expression, from the face image analysis process. The ability of a system to detect a neutral face further directly implies that the system has the capability to detect if there is a dramatic expression on a face.

PROBLEMS WITH THE PRIOR ART

Face recognition systems and facial expression recognition systems can achieve high recognition rate for good quality, frontal view, constant lighting, and subtle expression or expressionless face images. The performance of face recognition system significantly decreases for side views, dramatic expressions on the face, and bad-lighting face images.

A typical prior art face recognition system is described in U.S. Pat. No. 5,164,992 to Turk and Pentland. A typical prior art face recognition system to recognize faces with different facial expressions is described in (Yacooob, Lam, and Davis). This reference is incorporated by reference in its entirety.

Y. Yacooob, H. Lam, and L. Davis, "Recognizing Face Showing Expressions," Proc. Int. Workshop Automatic Face and Gesture Recognition, 1995. (Yacooob, Lam, and Davis)

U.S. Pat. No. 5,164,992 to Turk and Pentland presents a face recognition scheme in which face images are projected

onto the principal components of the original set of training images. The resulting eigenfaces are classified by comparison with known individuals. They present results on a database of 16 subjects with various head orientations and under different scale and lighting conditions. Their images appear identical otherwise with little variation in facial expression, facial details, pose, etc. For lighting, orientation, and scale variation their system achieves 96%, 85% and 64% correct classification, respectively. A problem with this prior art is that the recognition rates are highly dependent on the similarity of the enrolled and test face images, i.e., faces with the same expression and appearance. Another problem with this prior art is that the background significantly interferes with the recognition process.

The work (Yacooob, Lam, and Davis) compares the performance of face recognition on segmented faces with expressions to segmented neutral faces by using an eigenface-based approach and a feature-graph based approach. For both algorithms, it is observed that recognition performance degrades when the segmented face images have a dramatic, or different expressions compared to segmented face image with neutral expression. Automatic neutral face detection can find the neutral face (if a neutral face exists) or the nearest neutral face (if there is no a neutral face) from the video or images but it assumed here that the enrolled face has the neutral expression. Hence, a problem with this prior art is that it is assumed that a person's face is enrolled in a face recognition system with a neutral expression on the face. That is, there is no model developed in this work that captures and represents the neutral expression.

There are several patents on face identification and recognition that address the problem of faces with dramatic expressions. One such patent is U.S. Pat. No. 5,410,609 to Kado et al., it develops a system to identify individuals from facial characteristic points. An expressionless face of each individual is needed in this system. A total of 30 characteristic points on the face contour, eyebrows, eyes, nose, and mouth are used. A database of individuals wherein characteristic points of expressionless facial image are stored represents the enrolled population. Then for each input image, the differences between characteristic points in the current image and that in the expressionless images are calculated. In this system, two major problems exist. The first problem is that this face recognition system depends on the availability of an expressionless face image.

The second problem is that the characteristic points they use are difficult to reliably extract in real imagery. For example, face contours that are covered by hair cannot be extracted.

In the past decade, much progress has been made to build computer systems to understand and use the natural form of human communication through facial expression. Most of the facial expression analysis systems are focussed on the six universal expressions (happiness, sadness, disgust, anger, surprise, and fear). Recently, some researchers have addressed detection of subtle facial expression movements based on FACS (Facial Action Coding System). A problem is that all these current facial expression analysis algorithms need the neutral face to recognize facial expressions. No system can detect a neutral face automatically. All the neutral faces are manually labeled. Also for some video or image sequences, there is no neutral face. The facial expression analysis system will not work if no image or video of the neutral face is available.

Some prior art systems for facial expression analysis are (Suwa et al.), (Donado et al.), (Yacooob et al.), and (Tian et

al.). A significant problem with all these techniques is the assumption that there is a neutral face available for each subject. Articles describing these systems are the following:

M. Suwa, N. Sugie, and K. Fujimora, "A Preliminary Note on Pattern Recognition of Human Emotional Expression," Proc. Int'l Joint Conf. Pattern Recognition, pp. 408-410, 1978. (Suwa et al.)

G. Donado, M. Bartlett, J. Hager, P. Ekman, and T. Sejnowski, "Classifying Facial Actions," IEEE Transactions on Pattern Analysis and Machine Intelligence, Vol. 21, No. 10, pp 974-989, October 1999. (Donado et al.)

Y. Yacoob and L. Davis, "Recognizing Human Facial Expression from Long Image Sequences Using Optical Flow," IEEE Transactions on Pattern Analysis and Machine Intelligence, Vol. 18, No. 6, pp.636-642, June 1996. (Yacoob et al.)

Yingli Tian, T. Kanade and J. F. Cohn, "Recognizing Action Units for Facial Expression Analysis", IEEE Transactions on Pattern Analysis and Machine Intelligence, Vol. 23, No. 2, pp. 97-115, February, 2001. (Tian et al.)

Suwa et al. present an early attempt to analyze facial expressions by tracking the motion of twenty identified spots in an image sequence of a facial image. The work by Yacoob and Davis uses optical flow to track the motion of the surface regions of facial features (eyebrows, eyes, nose, and mouth) to understand the basic expressions. Both Donado et al. and Tian et al. develop facial expression systems to recognize subtle facial expression changes based on FACS. Both of these systems assume that the neutral face expression is available. That is, both systems assume that the first frame of the sequence contains a neutral expressionless face.

A problem with the prior art of current user interfaces is that the interfaces do not adept or react to the user's emotional state because of the difficulties of facial expression analysis. A problem with prior art image/video retrieval techniques cannot search faces with specific expressions, again because of the difficulties of facial expression analysis.

These references are herein incorporated by reference in their entirety.

OBJECTS OF THE INVENTION

An object of this invention is to improve facial expression analysis and to allow the design of facial expression analysis systems to work without manual interference.

An object of this invention is a new system and method for detecting neutral expressionless faces in images and video, if neutral faces are present in the image or video.

An object of this invention is a new system and method for detecting faces close to expressionless faces in images and video, if there is no neutral face present in the image or video.

An object of this invention is to improve the performance of face recognition authentication and identification systems.

An object of this invention is to allow current computer user interfaces the use of automated facial expression analysis without calibrating such interfaces with the neutral face of the user.

An object of this invention is to allow image and video retrieval systems to automatically label facial expressions thereby facilitating retrieval based on facial expressions.

SUMMARY OF THE INVENTION

The present invention is a system and method for automatically detecting neutral expressions in (still or moving)

digital images. The computer system has an image acquisition unit. A face detector receives input from the image acquisition unit and detects one or more face subimages of one or more faces in the image. A characteristic point detector receives input from the face detector and localizes and positions the face subimages with respect to a coordinate system and estimates characteristic facial features points in each detected face subimage. At least one of the facial features is the mouth of the face. A facial feature analyzer determines the shape of the mouth and a position of the mouth with respect to a reference in the coordinate system and creates a representation of the shape of the mouth and the position of the mouth. Finally, a face classification unit classifies the representation of each face subimage into one of a neutral class and a non-neutral class.

BRIEF DESCRIPTION OF THE DRAWINGS

The foregoing and other objects, aspects and advantages will be better understood from the following detailed description of a preferred embodiment of the invention with reference to the drawings, in which:

FIG. 1 is a drawing of a computer user where the computer has an attached camera that views the user's face.

FIG. 2 shows a more general setup where a person and the person's face are monitored by camera(s) in the environment.

FIG. 3A is a drawing of a person's face without expression, i.e., a neutral face (prior art).

FIG. 3B shows drawings of the six, prior art, universal face expressions: happy, sad, surprise, disgust, fear and anger (prior art).

FIG. 4 is a block diagram of the neutral face detector system.

FIG. 5A is a block diagram of a prior art face detector in digital images or video, which has as output the face image and the face position & pose parameters.

FIG. 5B is a block diagram of a prior art face characteristic point detector, which has as output the location of six points on the face image of FIG. 5A.

FIG. 6 explains how the outputs of the face detector and the characteristic point detector are used to normalize the face image to a fixed resolution and how nine zones in the normalized face image are determined.

FIG. 7A shows a preferred way to determine image zones to measure five distances between face characteristic points and it shows a preferred way to determine image zones that are used to compute edge direction histograms.

FIG. 7B shows how two additional distances between the inner eyebrows and the line connecting the centers of the eyes are determined.

FIG. 7C shows a pictorial explanation and a flow chart of the image zone edge histogram computation.

FIG. 8 show a system diagram of general methods to determine the image zones.

FIG. 9 shows a preferred method for computing facial features.

FIG. 10 is a generic classifier that takes as input facial features and determines whether the face is neutral.

FIG. 11 shows a flow chart of the neutral face detector system.

FIG. 12 shows a system diagram for training the neutral face detector system.

FIG. 13 is a neutral face classifier that compares the features associated with an unknown expression to features associated with neutral and non-neutral expressions.

FIG. 14 shows a neutral face classifier that compares the features associated with an unknown expression to features associated with neutral and non-neutral expression through a neural network and through nearest-neighbor classification.

DETAILED DESCRIPTION OF THE INVENTION

Automatically detecting neutral, expressionless faces in digital images and video is important in several applications such as face recognition, facial expression analysis, user interfaces, image retrieval, and so on. However, no neutral face detector or neutral face classifier is known in the prior art. This invention describes a system and method for automatically detecting neutral expressionless faces in digital images and video, or for automatically classifying face images as expressionless. First, a prior art face detector is used to detect the pose and position of a face from an input image or video. A prior art system is then used to find the facial components (i.e., eyes, eyebrows, mouth) in the detected faces. Second, the detected face is normalized to a standard size face in canonical position. A set of geometrical facial features and three histograms in zones containing the mouth are then extracted. These geometric face features are the height of the left eye, the height of the right eye, the distance between the left corner of the mouth and the line segment connecting the eyes, the distance between the right corner of the mouth and the line segment connecting the eyes, and the width of the mouth. The three histograms are the shape histogram of the left portion of the mouth, the shape histogram of the middle portion of the mouth, and the shape histogram of the right portion of the mouth. Finally, by feeding these features to a classifier, the system detects if there is the neutral expressionless face.

Digital cameras are becoming cheaper, smaller and more and more abundant. Already, computers can be bought that include a digital camera as standard equipment. It can be expected that future computers will come equipped with multiple cameras. Environments, such as department stores or airports, are also rapidly being equipped with cameras. These cameras are controlled, or will be controlled, by computers. In addition, many of these cameras will have pan, tilt and zoom capabilities that can be controlled by computers. Consequently, multiple video streams of objects in the environment, viewed from different directions at various resolutions, will be available in real time and in parallel.

Computational power, storage capacity, input/output speeds and network speeds are all also rapidly increasing. This will make it possible to automatically process and interpret these many video streams in real time. Applications of these technologies are plenty; among these applications are surveillance and "attentive computing." The latter includes, among other things, the use of these cameras to aid people in the environment (computer users, customers) in their productivity and overall experience and the aid to the owner of the environment in operating the environment effectively and safely. Examples are personalization of the environment based on the visual identification of a person and recognizing premier or undesirable customers in retail environments.

Attentive computing also refers to the ability of the environment to computationally react and adept to a person's emotional state or to the emotional state of multiple persons. A person's emotional state is correlated to the person's facial expression. As noted above, there are six

universal expressions, happy, sad, surprise, disgust, fear and anger. In addition to these expressions is the neutral expression or 'no-expression,' which could be defined as the expression on a face when none, or few, of the facial muscles are contracted. Computer systems that detect what expression is on the digital image of a face depend on, a manually selected, availability of an image of the face with a neutral expression (without expression). Face recognition systems work best when both the enrolled face and the face to be authenticated have no expression. The ability to detect if a face image has no expression has, in general, many applications since it eliminates one complicated degree of freedom, the facial expression, from the face image acquisition process.

The current invention is concerned with the automatic detection of the neutral expression in images of faces in digital images. This invention is better understood by the included drawings. Referring now to these drawings, FIG. 1 shows a picture of a computer user where the computer has an attached camera that views the user's face. That is, the user's **100** face **105** is in the field of view of camera **110**. The user interacts with the computer using his hands **115** and keyboard **120** and possibly a computer mouse (not shown). That is, the user input devices are limited to keyboard and mouse manipulated by the user's hands. The computer interacts with the user **100** through a user interface displayed on computer monitor **150**, the output device. Another input device is the camera **110** that views the input scene, illuminated by light source **160**, containing the user's face. Through this input video stream, a continuous stream of digital images containing the user's face is available to the computer. This video stream can be used for screen savers based on face presence detection, user authentication based on face recognition and computer reaction to the user based on the expression on the user's face.

Turning our attention to FIG. 2 here is shown an environment **200** where there are multiple input digital cameras **210** and **220**. These cameras could have zoom, pan, tilt capabilities, and, consequently, have the ability to view any objects (like the person's **240** face **250**) in the environment at any scale. Hence, the person **240** has the potential capability to interact with the environment and associated computer systems through the user's face **250**, hands **260** and other body parts. The person **240** in this environment **200** has no means like keyboard or computer mouse to interact with the environment, which is the case in traditional human computer interaction. One way for the person **240** to, actively or passively, communicate with the environment and associated computing systems is through facial expressions, the subject of this invention.

FIG. 3A shows the drawing of an image **300** of a human face with a neutral expression **305** or no expression. (The notion of a neutral face is prior art.) The hair **310** may or may not cover much of the ears (not shown) and eyebrows **313**. Hence, for automated machine classification of human expressions these features are of little value. In a preferred embodiment, the eyebrow features that are of use are the inner corners **316**. Further face features that are of use for automated neutral face detection are the shape and distance of the eyes **319** and the mouth **322**.

Moving on to FIG. 3B here are shown drawings of the six prior art universal expressions. These expressions are: the happy expression **330**, the sad expression **340**, the surprise expression **350**, the disgust expression **360**, the fear expression **370**, and the anger expression **380**. As noted above, these expressions are universal over the cultures and races, in that, these expressions are universally understood

between people without the need for communication through some common language. Each expression is characterized by, among other face features, the shape and location of the eyebrows **313**, the shape of the eyes **319** and the shape of the mouth **322** (FIG. 3A). A happy face **330** is mainly characterized by the circular shape **334** of the mouth, i.e., the mouth is of the shape of a circular arc with the mouth corners **338** curved up. A sad, or unhappy, face **340**, on the other hand, is also characterized by the circular shape **344** of the mouth, however, now the mouth is of the shape of a circular arc with the mouth corners **348** curved down. The surprise expression **350** is characterized by more changes in the face appearance from the neutral face **305**. The mouth **353** is generally in an open position and of circular or oval shape. The eyes **356** are opened wider than in the neutral face and, consequently, the eyebrows are raised **359** and somewhat broadened. The disgust expression **360** differs in different ways from the neutral face **305**. The mouth may be somewhat opened or closed and of oval shape **363** while there may be some convexity on the upper lip **364**. The upper lip **364** moves up. The eyes **366** may be somewhat closed, i.e., of a more oval shape than in the neutral face **305**. The eyebrows **369** may therefore be somewhat lowered. For the fear expression **370**, again there are deformations from the neutral face **305**. The mouth in this case is of a bent oval shape **373**, where the curvature **374** is downward. That is, the mouth corners are slightly down with respect to a neutral mouth shape. The shape of the eyes **376** is somewhat widened indicating that the subject is fearful of something. The eyebrows **379** for the fear expression are straighter than is the case for the neutral face and may be pointing upward a little. Finally we have the expression of anger **380**. This expression is again a deformation of the neutral face, with the shape of the mouth **383** straight and narrow. The eyes **386** somewhat more closed than in the neutral expression. Just like the mouth **383**, the eyebrows **389** are also straightened out. The inner sides of the eyebrows is lowered while the outsides are higher than in the neutral case.

FIG. 4 is a block diagram of the novel neutral face detection system. It shows the image/video acquisition device (camera) **410** with lens **420** (possibly a zoom, pan and tilt lens) which is used for imaging the objects such as human bodies or body parts **100**, **105**, **115**, **240**, **250** and **260**. The image/video, acquired by acquisition device **410** is digitized into a fixed number of pixels, each quantized into a fixed number color intensity values by a frame grabber. This is the case if image acquisition device **410** is analog. If the camera is digital, the image/video is directly input into face detector system **430** through USB or firewire. This face detector system **430** determines if there are one or more faces in the image. If there are faces in the image, the characteristic point detector **440** localizes a number of prior art characteristic points. System **440** further establishes a local coordinate system for each face image detected by face detector **430**. The image area around each set of characteristic points, for each face characterized by a local coordinate system is then analyzed by facial feature analyzer **450**. This system **450** computes one or more facial features and based on the features, classifier **460** determines if the corresponding face depicts a neutral face **470** or a non-neutral face **480**.

FIGS. 5A and 5B refer to prior art image/video processing systems for detecting faces and specific characteristic points in the faces that are found in the images. These systems are used in the neutral face classification system subject of this invention.

FIG. 5A is face detector that can be found in the prior art. Like the neutral face classifier of FIG. 4, this system takes

images or video containing faces **510** as input to a computer system **500**. A face detector module **520** detects the presence of a face. If a face is detected **530** the system **500** outputs parameters derived from the face image. If no face match is detected **535**, the output the computer system **500** with face detection module is 'No Face' **537**. If a face match is detected **530**, the computer system **500** determines face parameters. These parameters are output as **540** and **545**. Output **540** is the face image appearance **542** in a bounding box **544** for a still image. In case of input video, it is a face appearance image **542** with bounding box **544** for each input frame. The face position and pose output **545** are the location in the image of the face with respect to an image coordinate system and an estimated rotation of the face within the image and possibly rotation of the 3D head with respect to the image axes. Alternatively, the parameters could be defined within some world coordinate system that is related to the image coordinate system through a projection.

Continuing with FIG. 5B where is shown a prior art face characteristic point (landmark) detector. This is a computer system **555** that takes as input **550**, which is the output (**540** and **545**) of the face detector system described in FIG. 5A. When there is a face present in image/video **510**, which is indicated to system **555** by a non NIL value of input **550**, a prior art characteristic point detector **560** computes the locations of salient landmarks (points). These points are output **565** as a list of image locations and are expressed in terms of image/frame **569** coordinates. The characteristic points include as a first set the inner point of the right eyebrow P_1 **570** and the inner point of the left eyebrow P_2 **575**. As a second set of characteristic points, we have the center of the pupil of the right eye P_3 **580** and the center of the pupil of the left eye P_4 **585**. A final set is the right corner of the mouth P_5 **590** and the left corner of the mouth P_6 **595**. (Here left and right is defined with respect to the person whose face is imaged.)

Further, a window **599** is selected such that it encloses the face image with certain tolerances. This window **599** is associated with a face coordinate system x, y **501**.

FIG. 6 explains how the outputs of the face detector and the characteristic point detector are used to normalize the face image to a fixed resolution and how the zones in the normalized face image are determined. Image **600** is the input image or a frame of the input video (i.e., an image **510**). The input image **600** contains the appearance of a human face (face image) **605**. Furthermore, it contains a smaller image or window **599** that encloses within specified tolerances the visual appearance of the human face. The window is associated with coordinate system **501**. This window is selected in such a way that the important features for face expression are containing therein. We refer in the rest of this invention description to this window as the face image or face appearance image. (This face image can be at the original resolution of input image **600** or it can be at the resolution of image **620** after re-sampling, or normalization, of transform **615**.)

This face image **599** is normalized **615** to a fixed size M **623** by N **626** face image **620** by re-sampling. That is, the image **599** is sampled at new pixel positions by either interpolating between pixels or weighted averaging of multiple pixels. The face image **620** size is selected in such a fashion that the distance from the left corner **630** of the left eye to the right corner **632** of the right eye is approximately three times the distance d **629**. This distance d **629** is also half of the width of the centers of the eyes which, in most faces, is also the distance **634** between the inner corner of the eyes. The image width N **626** is further selected such that

$N=4 \times d$. In a preferred embodiment of this invention $M=N=128$ and $d=32$ pixels. The distance between the centers of the eyes **636** (x_1, y) and **638** (x_2, y) is then approximately also equal to $2 \times d$, i.e., $x_2 - x_1 = 2 \times d$ which is 64 pixels.

The next step is to place **640** a sub-image **645** of size $K \times L$ in the face image **620**. Here L **646** is selected such that $L=3 \times d$ and K can be chosen to be approximately equal to L **646**. In the preferred embodiment of this invention $K=M=128$ and $L=3 \times d=96$. The sub-image **645** contains zones (windows) **651, 652, 653, 654, 655, 656, 657, 658, and 659** of size $K/3 \times L/3$. The sub-image **645** is then so placed that the eye features falls in zone **651** and **653**, respectively. The mouth features then fall in zones **657, 658** and **659**.

The process described in the following figures uses the zones and the characteristic face points for further feature estimation. That is, FIGS. **7A, 7B** and **7C** are concerned with determining the facial features that are used to classify if a facial expression is neutral or not.

FIG. **7A** shows the facial features of the facial sub-image **700** that are used for neutral facial expression detection. The feature are extracted, in particular, from zones **702, 704, 706, 708, and 710**. First five distance measures L_1 (**711**), L_2 (**712**), L_3 (**713**), L_4 (**714**) and L_5 (**715**) are estimated. (In the following 'left' and 'right' refer to the left and right side of the face sub-image.) These distances are: 1) the vertical distance **711** from the left eye pupil **720** to the left corner **724** of the mouth; 2) the vertical distance **712** from the right eye pupil **722** to the right corner **726** of the mouth. [These two distances are computed by determining the line **701** connecting the centers of the eyes **720** and **722**.] 3) the distance **713** from the left corner of the mouth **724** to the right corner of the mouth **726**; 4) the height "openness" **714** of the left eye, and 5) the height "openness" **715** of the right eye. Further, three shape histograms of the mouth edges are computed. These are one shape histogram H_1 **717** from the mouth edges **721** in zone **706**, one shape histogram H_2 **718** from the mouth edges **722** in zone **708**, and one shape histogram H_3 **719** from the mouth edges **723** in zone **710**. The features that are output of the step described in this figure are input to the classifier. These features are $f_1=(L_1+L_2)/2$; $f_2=L_3$, $f_3=L_4$ and $f_4=L_5$ and the histograms H_1 , H_2 and H_3 . FIG. **7C** explains the process of deriving these shape histograms.

FIG. **7B** gives a detail of FIG. **7A** and shows how two additional features are computed from the face image. The figure shows the center **720** of the left eye, the center **722** of the right eye and the line **701** connecting these centers. Using this line, the distance from the left inner eyebrow point **742** to the line L_6 **732** is determined. Further, using this line, the distance from the right inner eyebrow point **743** to the line L_7 **733** is determined. This gives two additional facial features $f_5=L_6$ and $f_5=L_7$.

Moving on to FIG. **7C**. On the left a pictorial description of the shape histogram computation process is shown; on the right a flow diagram of the shape histogram computation process is shown. Input to the shape histogram computation process are the edge elements **730** in zone **706**, zone **708** or zone **710**. These zones are used for the computation of histogram **717**, histogram **718**, and histogram **719**, respectively. The edge elements **730** in a zone each have a location (x, y) and a direction d . The direction is quantized into 0 degrees **732**, 45 degrees **734**, 90 degrees **736** and 135 degrees **738** in step **740**. Next, the label '0' is assigned to 0 degrees **732**, label '1' is assigned to 45 degrees **734**, label '3' is assigned to 90 degrees **736**, and label '3' is assigned to 135 degrees **738** and these labels are assigned to the edges.

Subsequently, is step **745** for each label, the number of edges that have this label are counted. These counts are accumulated in buckets **746, 747, 748, 749** of shape histogram **750**. That is, bucket **0** (**746**) will have the number of edges with quantized direction equal to zero, bucket **1** (**747**) will have the number of edges with quantized direction equal to one, and so on. As a final step histogram **750** is normalized by the number of edges N in the corresponding zone.

The flowchart on the right in FIG. **7C** describes the computational process of determining histograms **717, 718** and **719**. In step **755** the edges in zone **706, 708** or **710** are detected, these edges are denoted as $\{e_1, \dots, e_N\}$ with a total of N edges. Initialization is performed in steps **760** and **765**. Step **760** sets the histogram values $H(0)=H(1)=H(2)=H(3)=0$ (here I in **760** is 3 because the highest label is 3) and step **765** sets $n=1$. Subsequently the process enters a loop with variable n . In **770** the histogram bucket $H(l(e_n))$ is incremented by one, where $l(e_n)$ is the label of edge direction $d(e_n)$ of edge e_n . The test **775** then determines if $n=N$. If not **780**, the loop variable n is incremented by one in step **785** and step **770** is repeated. If, on the other hand $n=N$ in test **775** ('Yes' **709**), the process branches to step **795**. This step normalizes the histogram by dividing the number in each bucket **746, 747, 748, 749** by N .

The outputs of the processes of FIG. **7** are the five distance features $f_1=(L_1+L_2)/2$; $f_2=L_3$, $f_3=L_4$ and $f_4=L_5$ and the histograms H_1 , H_2 and H_3 . Each histogram itself is four features, that is, $H_1(0)=f_5$, $H_1(1)=f_6$, $H_1(2)=f_6$ and $H_1(3)=f_7$; $H_2(0)=f_9$, $H_2(1)=f_{10}$, $H_2(2)=f_{11}$ and $H_2(3)=f_{12}$; and $H_3(0)=f_{13}$, $H_3(1)=f_{14}$, $H_3(2)=f_{15}$ and $H_3(3)=f_{16}$. These 16 features are the $K=16$ features that are the input to the classifier of FIG. **10**.

Whereas FIG. **7A** shows a preferred method for determining image zones from the facial sub-image **700**, FIG. **8** gives a system diagram for determining image zones in general. This zone selector **800** takes as input a sub-image **700** of size K (648) \times L (646) in the face image **620**. Zone selector **800** determines zones within the face sub-image **700**. On the left **803** in FIG. **8**, three zones are established in face sub-image **700**. These zones are **810, 820** and **830**. The zones contain the eyes, the nose and the mouth respectively. On the right **806**, five zones **840, 850, 820, 860** and **870** are established. Zones **840** and **850** contain the left and right eye, respectively. As in **803**, zone **820** contains the nose. Zones **860** and **870** contain the left and the right side of the mouth, respectively. The zone selector determines the zones based on an implicit model of a face. The zones can be simple rectangular image regions where the regions may or may not be overlapping. The zones can further be based on the presence of facial features such as edges. For example, around the center of an eye a region can be constructed such that as much edge detail is contained as possible within the region. Other methods for selecting regions or zones are obvious to those skilled in the art.

FIG. **9** describes in more detail the process by which the facial features are computed. The facial features that are computed by this process are the preferred features of this invention. Input to the system are face sub-image **700** with zones **651, 653, 657, 658** and **659**. This sub-image is of size K 648 rows and L 646 columns. Also input to the system are the characteristic points P_1, P_2, P_3, P_4, P_5 and P_6 **905**. The characteristic points include as a first set the inner point of the right eyebrow P_1 **570** and the inner point of the left eyebrow P_2 **575**. As a second set of the characteristic points, we have the center of the pupil of the right eye P_3 **580** and the center of the pupil of the left eye P_4 **585**. A final set is the right corner of the mouth P_5 **590** and the left corner of the mouth P_6 **595**.

Step **910** in process **900** determines distances (lengths) L_1 **711**, L_2 **712**, L_3 **713**, L_4 **714** and L_5 **715**. First the line **701** that connects the center of the pupil of the right eye P_3 **580** and the center of the pupil of the left eye P_4 **585** is determined. Distance L_1 **711** is the distance between line **701** and the left corner of the mouth P_6 **595**. Distance L_2 **712** is the distance between line **701** and the right corner of the mouth P_5 **590**. Distance L_3 **712** is the distance between the inner point of the right eyebrow P_1 **570** and the inner point of the left eyebrow P_2 **575**. Distance L_4 **714** is the height of the left eye and is determined by any of ellipse fitting to eye edges, determining the moments of the eye edges, determining the variance of the eye edges in the vertical direction. Similarly, distance L_5 **715** is the height of the right eye. Other methods for determining the height of the eyes are within the realm of this invention.

Step **920** in process **900** determines distances (lengths) L_6 **732** and L_7 **733**. Distance L_6 is computed as the distance between line **701** and point P_2 **570**. Equivalently, distance L_7 is computed as the distance between line **701** and point P_1 **575**.

Step **930** of process **900** computes the three edge histograms H_1 , H_2 , H_3 by processing the edges in zones **657**, **658** and **659**, respectively. This processing is achieved as explained in FIG. **7C**. The mouth shape can be represented using many shape features. Shape histograms of the mouth, or portions of the mouth, is one way of representing shape. Other facial features that represent shape and distance for expression analysis are obvious to those skilled in the art after reading this invention.

Finally, step **940** of process **900** outputs the face features f_1, f_2, f_3, \dots as they are determined from the distances L_i and histograms H_j or other shape representations/features.

FIG. **10** shows the prior art classifier that decides, based on the features extracted from the zoned face image, if a detected face has a neutral expression or not. The classifier **1000** again is a module a computer system and takes as input the features $f_1, f_2, f_3, \dots, f_K$ (**1010**, **1012**, **1014**, \dots , **1020**) computed by the systems described in FIGS. **7A** and **7B**. For the preferred system of FIG. **7**, $K=19$. The classifier **1000** can be any of a number of classifiers found in the prior art. These classifiers are enumerated in the background of this invention. A preferred classifier in this invention is a neural network. This output is 'YES' **1030** when the face expression of the face in the input image/video is neutral and 'NO' **1040** when the face expression is not neutral. FIGS. **12-14** better explain the training and operation of this classifier.

A flowchart of the complete neutral face detector **1100**, subject of this invention, is shown in FIG. **11**. The input to the systems is an image or video **1110** that may or may not contain images of human faces. This input signal **1110** is first processed by face detector **1120** to determine if there is an image of a face or images of faces present in the input signal. If this is the case, the face detector **1120** passes the image or images of the face appearance or appearances plus location and pose information on the face(s) to the characteristic point estimation process **1130**. This process **1130** uses the output of process **1120**, in particular the face appearance image(s), to estimate the location of the characteristic points on the appearance image(s) that are important for facial expression classification. For each face image, these The characteristic points are the corners of the mouth, the center of the eyes (pupils) and the inner endings of the eyebrows. The following process, process **1140**, normalizes each face image, which is the output of the face detection process **1120**. Here face image normalization is the re-sampling of

the face appearance image to an image of fixed, predetermined resolution $M \times N$. These normalized images of face appearances are the input to the zones selection process **1150**. This zones selection process is the estimation of the best location for a fixed $K \times L$ sub-image within each of the re-sampled normalized face images determined by process **1140**. This fixed $K \times L$ sub-image contains (3×3) equal-sized windows that contain important facial features for face expression analysis. These windows are passed to feature computation process **1160**. The features are shape histograms of the mouth shape and (normalized) distance measures between facial characteristic points (as explained in FIGS. **7A** and **7B**). The estimated features from the feature computation process **1160** are the input to the expression classifier **1170**. (A block diagram of this classifier is shown in the earlier described FIG. **10**.) The output of the classifier **1170** is the decision whether a face image is of neutral expression 'NEUTRAL' **1180** or the face image is of some expression other than neutral **1190** 'EXPRESSION.' Such non-neutral expressions may be sad, happy, fear, etc.

FIG. **12** shows a system diagram for the training phase **1200** of the neutral face detector system. For this training, a collection **1210** of hand-labeled images of neutral faces and a collection **1220** of hand-labeled images of non-neutral faces is required. Using process **900**, two sets of feature sets, set **1240** and set **1250** are computed. The set $\{F_1, F_2, F_3, \dots\}$ **1240** are the feature sets (or feature vectors F_i) associated with the neutral face images, the set $\{G_1, G_2, G_3, \dots\}$ **1250** are the feature sets (or feature vectors G_j) associated with the non-neutral face images. These two sets **1240** and **1250** are used by the classifier parameter estimation process **1260** to determine the parameters of a classifier that distinguishes between neutral faces and non-neutral faces. This classifier (the general classifier **1000** in FIG. **10**) then implicitly or explicitly contains a model of a neutral face **1270** and a model of a non-neutral face **1280**. Depending on the classifier, these models are used differently. The general case of the use of models is explained in FIG. **13** while more specific uses of models in classifiers are explained in FIG. **14**.

Turning our attention now to FIG. **13**. Herein is shown a neutral face classifier **1300** that compares the features associated with an unknown expression to features or a model associated with the neutral expression and to features or a model associated with the non-neutral expression. This neutral face classifier takes as input a face image **1310**. The feature computation process **900** computes the features $f_1, f_2, f_3, \dots, f_n$, **1320**, denoted as vector F . A "Compare" process **1330** then compares this vector F **1320** to a model of a neutral face **1340** and to a model of a non-neutral face **1350**. Based on this comparison, classifier **1000** either classifies input face **1310** as having a neutral expression **1360** or classifies input face **1310** as having a non-neutral expression **1370**. Comparing is done in the form of distance measures between the input features $f_1, f_2, f_3, \dots, f_n$ **1320** and the model representations, correlation measures between the input features $f_1, f_2, f_3, \dots, f_n$ **1320** and the model representations or any nonlinear function of the input features $f_1, f_2, f_3, \dots, f_n$ **1320** and the model representations. FIG. **14** describes two specific instances of classifiers, neural networks and k nearest-neighbor classifiers.

FIG. **14** shows a neutral face classifier that compares the features associated with an unknown expression to features associated with neutral and non-neutral expression through a neural network **1400** and shows a neutral face classifier that compares the features associated with an unknown expression to features associated with neutral and non-neutral expression through nearest neighbor classification **1450**.

System **1400** is a neural network **1410** trained in the classification phase **1200** (FIG. **12**) with a set **1210** of neutral face images and a set **1220** of non-neutral face images. Input **1420** to the neural network are the features $f_1, f_2, f_3, \dots, f_n$, **1320**, i.e., feature vector F . Output of the neural network **1410** is the classification 'neutral' **1430** or 'non-neutral' **1440**. The output could take on the values '1' for 'neutral,' and '0' for 'non-neutral.'

System **1450**, finally, is a nearest neighbor classifier. It is again trained in the classification phase **1200** (FIG. **12**) with a set **1210** of neutral face images and a set **1220** of non-neutral face images. Training, in this instance, means that the feature vectors associated with neutral face training images $\{F_1, F_2, F_3, \dots\}$ lie in cluster **1470** in feature space **1455**. The feature vectors associated with the non-neutral face training images **1220**, the set $\{G_1, G_2, G_3, G_4, \dots\}$ also lie in the feature space, but do not form a cluster. Upon classification of an unknown face image, or an unknown feature vector F **1460**, the distances **1490** are computed from the vector F to all the prototype labeled vectors F_1, F_2, F_3, \dots and $G_1, G_2, G_3, G_4, \dots$ in feature space **1455**. In the figure, the unknown vector F has as nearest neighbors G_2 **1480** and G_3 **1485**. Based on the two nearest neighbors, the vector F is then classified as non-neutral. Output of the k nearest neighbor classifier **1450** is the classification 'neutral' **1430** or 'non-neutral' **1440**.

Having thus described our invention, what we claim as new and desire to secure by Letters Patent is as follows:

1. A system for automatically detecting neutral, expressionless face images in digital images, the system comprising:

- an image acquisition unit;
- an face detector receiving input from the image acquisition unit, detecting one or more face subimages of one or more faces in the image;
- a characteristic point detector that receives input from the face detector and that estimates one or more characteristic facial features as characteristic points in each detected face subimage, one of the characteristic points being a first and a second mouth corner on a mouth of the face;
- a facial feature detector that detects one or more contours of one or more facial components;
- a facial feature analyzer that determines a mouth shape of the mouth from the contour of the mouth and creates a representation of the mouth shape, the mouth being one of the facial components; and
- a face classification unit that classifies the representation into one of a neutral class and a non-neutral class.

2. A system, as in claim **1**, where the mouth shape is determined by a width of the mouth, the first distance from the first mouth corner to a reference in the coordinate systems, and the second distance from the second mouth corner to the reference in the coordinate systems.

3. A system, as in claim **1**, where one or more of the characteristic facial features is an eye openness measure of an eye of the facial image and the representation includes the eye openness measure.

4. A system, as in claim **3**, where the eye openness measure of the eyes is measured by a normalized height of the eyes.

5. A system, as in claim **1**, where one or more characteristic facial features is derived from any one of an eye region and an eyebrow region in the face subimage.

6. A system, as in claim **1**, where the contours are extracted by an edge detector.

7. A system, as in claim **1**, where the characteristic facial features are estimated by template matching techniques.

8. A system, as in claim **1**, where the facial components include any one or more of the following: a mouth, an eye, an eyebrow, a nose, an ear, and a wrinkle.

9. A system, as in claim **1**, where a mouth position of the mouth is determined with respect to a geometric reference.

10. A system, as in claim **1**, where a mouth position of the mouth is determined with respect to an image coordinate system.

11. A system, as in claim **1**, where the characteristic points define one or more characteristic distances to one or more respective geometric references.

12. A system, as in claim **11**, where one or more of the characteristic distances is normalized to another of the characteristic distances.

13. A system, as in claim **11**, where the facial feature analyzer divides the face sub-image into two or more zones.

14. A system, as in claim **13**, where facial feature analyzer determines one or more component shapes from one or more respective component contours in one or more of the zones.

15. A system, as in claim **14**, where the component is the mouth and the shape of the mouth is extracted from three of the zones containing the mouth.

16. A system, as in claim **15**, where the shape of the mouth is determined by histogramming the contours of the mouth in each of the three zones containing the mouth.

17. A system as in claim **16** where the mouth shape is defined by three shape histograms each corresponding to one of the three zones containing the mouth obtained by quantizing the contour of the mouth into four directions.

18. A system, as in claim **15**, where a further component is one or more of an eye and an eyebrow that are extracted from three of the zones containing the eyes.

19. A system, as in claim **11**, where one or more of the characteristic distances is the normalized width of the mouth, the width of the mouth being the distance between the first and second mouth corners.

20. A system, as in claim **1**, where the characteristic points further include a location of each eye on the face, being eye characteristic points and one of the characteristic distances is a distance between the eye characteristic points, being an eye separation distance.

21. A system, as in claim **20**, where one or more of the other characteristic distances is normalized by the eye separation distance.

22. A system, as in claim **20**, where the eye characteristic points are located on the eye pupil.

23. A system, as in claim **20**, where a mouth-eye distance between the first mouth corner and a first eye is normalized by the eye separation distance, and the normalized mouth-eye distance is an additional feature used by the face classification unit.

24. A system, as in claim **20**, where a brow-eye distance between a first eyebrow and a first eye is normalized by the eye separation distance, and the normalized brow-eye distance is an additional feature used by the face classification unit.

25. A system, as in claim **20**, where a brow distance between the first eyebrow and the second eyebrow is normalized by the eye separation distance, and the normalized brow distance is an additional feature used by the face classification unit.

26. A system, as in claim **1**, where one or more normalized characteristic distances is used by the face classification unit classify if the face is neutral.

27. A system, as in claim **26**, where the face classification unit is one or more of the following classifiers: neural

19

networks, nearest neighbor methods, Bayesian inference methods, linear discriminant methods, perceptrons, support vector machines, and related variants.

28. A system, as in claim 26, where the face classification unit is neural network (NN).

29. A system, as in claim 1, where the face classification unit is used to enroll one or more subjects in a face-based authentication system with a neutral face.

30. A system, as in claim 1, where the face classification unit is used to authenticate one or more subjects in a face-based authentication system with a neutral face.

31. A system, as in claim 1, used as a user interface that reacts to one or more human emotion states.

32. A system, as in claim 1, used as a surveillance device.

33. A system, as in claim 32, used in one or more of the following: a financial institution, a bank a retail store, a credit card check, a check in, an air port, an air plane boarding check, a building access system, and a object access authorization system.

34. A system, as in claim 1, used as an information retrieval device.

35. A system, as in claim 34, where the information retrieval device includes any one or more of the following: a video retrieval of a frame containing a face image with a specified expression, an image of an image containing a face image with a specified expression.

36. A method for automatically detecting neutral, expressionless face images in digital images, the method comprising the steps of:

acquiring an image;

detecting one or more face subimages of one or more faces in the image;

estimating one or more characteristic facial features as characteristic points in each detected face subimage, one of the characteristic points being a first and a second mouth corner on a mouth of the face;

detecting one or more contours of one or more facial components;

determining a mouth shape of the mouth from the contour of the mouth;

creating a representation of the mouth shape, the mouth being one of the facial components; and

20

classifying the representation into one of a neutral class and a non-neutral class.

37. A system for automatically detecting neutral, expressionless face images in digital images, the method comprising:

means for acquiring an image;

means for detecting one or more face subimages of one or more faces in the image;

means for estimating one or more characteristic facial features as characteristic points in each detected face subimage, one of the characteristic points being a first and a second mouth corner on a mouth of the face;

means for detecting one or more contours of one or more facial components;

means for determining a mouth shape of the mouth from the contour of the mouth;

means for creating a representation of the mouth shape, the mouth being one of the facial components; and

means for classifying the representation into one of a neutral class and a non-neutral class.

38. A program storage device, readable by machine, tangibly embodying a program of instructions executable by the machine to cause the machine to perform a method for automatically detecting neutral, expressionless face images in digital images, the method comprising the steps of:

acquiring an image;

detecting one or more face subimages of one or more faces in the image;

estimating one or more characteristic facial features as characteristic points in each detected face subimage, one of the characteristic points being a first and a second mouth corner on a mouth of the face;

detecting one or more contours of one or more facial components;

determining a mouth shape of the mouth from the contour of the mouth;

creating a representation of the mouth shape, the mouth being one of the facial components; and

classifying the representation into one of a neutral class and a non-neutral class.

* * * * *